



UNITED STATES DEPARTMENT OF COMMERCE

National Oceanic and Atmospheric Administration
NOAA Marine and Aviation Operations
Marine Operations Center
439 W. York Street
Norfolk, VA 23510-1114

FEB 13, 2015

MEMORANDUM FOR: Commander Mark Wetzler, NOAA
Commanding Officer, NOAA Ship *Okeanos Explorer*

FROM:  Captain Anne K. Lynch, NOAA
Commanding Officer, NOAA Marine Operations Center-Atlantic

SUBJECT: Change Memo - Project Instruction for EX-15-02 Leg 1
Caribbean Exploration (Mapping)

Attached is the Change Memo for the final Project Instruction for EX-15-02 Leg 1, Caribbean Exploration (Mapping), which is scheduled aboard NOAA Ship *Okeanos Explorer* during the period of February 23 – March 11, 2015. Of the 16 DAS scheduled for this project, 16 DAS are funded by a Line Office allocation. This project is estimated to exhibit a Medium Operational Tempo. Acknowledge receipt of these instructions via e-mail to OpsMgr.MOA@noaa.gov at Marine Operations Center-Atlantic.

cc:





Project Instructions Change Memo

Date Submitted: February 13, 2015

Platform: NOAA Ship *Okeanos Explorer*

Project Number: EX-15-02 Leg I

Project Title: Caribbean Exploration (Mapping)

Project Dates: February 23 to March 11, 2015

Prepared by: Lindsay McKenna, NOAA
Expedition Coordinator
Office of Ocean Exploration & Research

A. Overview

A multibeam patch test and ensuring mission readiness of mapping systems for the FY15 Field Season has become a top priority focus of the cruise, because the previously scheduled patch test was canceled due to weather. The start of the cruise was delayed 5 days to fix the shaft on the port anchor windlass.

B. Cruise Period

This change memo contains changes to the Project Instructions for EX-15-02 Leg 1. EX-15-02 Leg 1 operations are expected to commence on February 23, 2015 at North Kingstown, RI and conclude March 11, 2015 in San Juan, Puerto Rico.

C. Days at Sea (DAS)

The departure date is delayed 5 days, so there are now 16 DAS scheduled for this project, all 16 days remain funded by a Line Office Allocation.

D. Operating Area

The multibeam patch test will be completed during the transit down to Puerto Rico in the vicinity of Veatch Canyon, see Figure 1 and Table 1. If the weather is unfavorable for a patch test, the patch test will be conducted near Puerto Rico at a later date and multibeam data will be post-processed with new offset values.

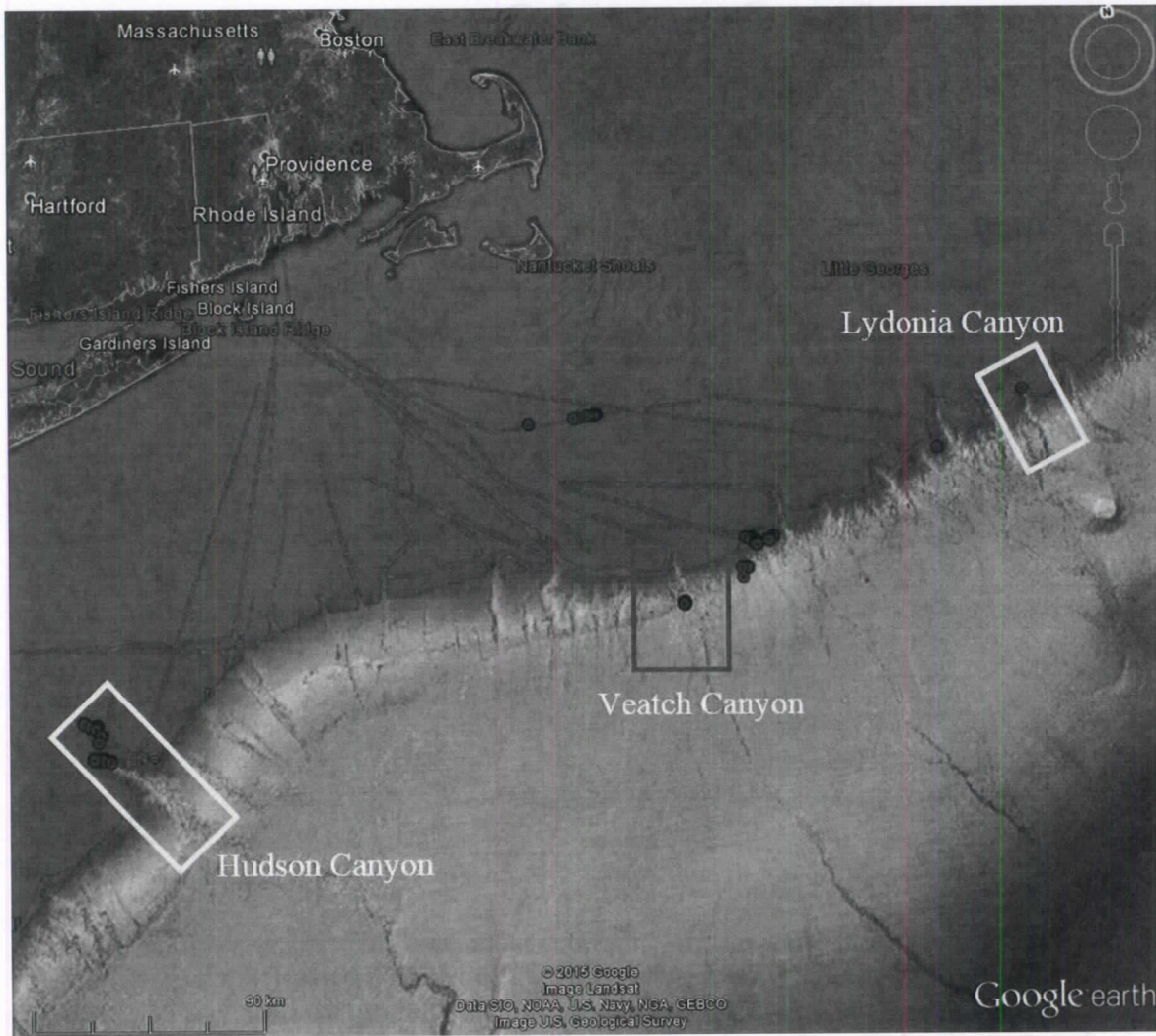

Figure 1: Operating area map. Multibeam patch test area indicated with red polygon. Yellow boxes are patch test weather contingency areas. Existing available bathymetry collected by Okeanos Explorer and University of New Hampshire Law of the Sea Project shown in background. Red dots indicate known gas seep locations previously discovered by *Okeanos Explorer*. Map produced in Google Earth Pro.

Table 1. Multibeam Patch Test / System Testing bounding box coordinates.

Multibeam Patch Bounding Box Coordinates		Remarks
70 3.7 W	39 58.4 N	Northwest Corner
69 12.2 W	40 11.5 N	Northeast Corner
68 57.4 W	39 40.4 N	Southeast Corner
69 51.0 W	39 25.3 N	Southwest Corner

E. Additional Objectives

1. Conduct sound velocity comparison cast between CTD and XBT. Near surface values will be compared to values from the thermosalinograph (TSG) and Reson SVP-70 probe. CTD and XBT comparison casts will be obtained at Veatch Canyon prior to collecting multibeam lines for the patch test.
2. Conduct multibeam system testing in vicinity of Veatch Canyon.
 - a. Conduct multibeam patch test.
 - b. Conduct EM 302 system noise testing (BIST tests).
 - c. Conduct multibeam reference surface survey.
 - d. Conduct crossline comparison.
3. XBT and CTD operations
 - a. Conduct CTD cast at Veatch Canyon prior to multibeam patch test.
 - b. Test the ship's 3 XBT hand-launchers.
 - c. XBT casts will be collected at regular interval of no more than 6 hours.
 - d. Testing and verification of CTD sensors
4. Collect water column data over known Veatch Canyon seeps using the EK80. The ship should collect data over the known seep location by running survey lines from several different orientations while obtaining EK 80 split-beam data. Repeat lines with EK 60 split-beam sonar for comparison. Approximately 6-8 hours of data acquisition at the seep location is anticipated.

F. Cruise Plan Itinerary *(All times and dates are subject to prevailing conditions and the discretion of the commanding officer)*

Sunday, February 22

- Mission personnel arrive to ship, prepare for expedition

Monday, February 23

- Morning departure from RI for Caribbean
- Swing compass
- Reach Veatch Canyon

Tuesday, February 24

- Conduct patch test, and CTD cast at Veatch Canyon
- Continue transit down to the Caribbean

Tuesday, March 3

- Arrive to San Juan, Puerto Rico, small boat transfer to bring NOAA NOS personnel onboard, depart for EK60 calibration area, start calibration

Wednesday, March 4

- Finish calibrating EK60, transit to glider deployment area, deploy glider

Thursday, March 5

- Transit to Charlotte Amalie, St. Thomas for small boat transfer

Friday, March 6

- Transit to survey area southeast of St. Croix, begin surveying

Tuesday, March 10

- Complete surveying, transit back to San Juan

Wednesday, March 11

- Arrive at port in San Juan

Thursday, March 12

- Personnel depart ship



UNITED STATES DEPARTMENT OF COMMERCE

National Oceanic and Atmospheric Administration
NOAA Marine and Aviation Operations
Marine Operations Center
439 W. York Street
Norfolk, VA 23510-1114

FEB 13, 2015

MEMORANDUM FOR: Commander Mark Wetzler, NOAA
Commanding Officer, NOAA Ship *Okeanos Explorer*

FROM: 
Captain Anne K. Lynch, NOAA
Commanding Officer, NOAA Marine Operations Center-Atlantic

SUBJECT: Project Instruction for EX-15-02 Leg 1
Caribbean Exploration (Mapping)

Attached is the final Project Instruction for EX-15-02 Leg 1, Caribbean Exploration (Mapping), which is scheduled aboard NOAA Ship *Okeanos Explorer* during the period of February 18 – March 11, 2015. Of the 21 DAS scheduled for this project, 21 DAS are funded by a Line Office allocation. This project is estimated to exhibit a Medium Operational Tempo. Acknowledge receipt of these instructions via e-mail to OpsMgr.MOA@noaa.gov at Marine Operations Center-Atlantic.

cc:





Project Instructions

Date Submitted: February 5, 2015

Platform: NOAA Ship *Okeanos Explorer*

Project Number: EX-15-02 Leg I

Project Title: Caribbean Exploration (Mapping)

Project Dates: February 18 to March 11, 2015

Prepared by: Lindsay McKenna, NOAA
Expedition Coordinator
Office of Ocean Exploration & Research

Approved by: Digitally signed by John McDonough
DN: cn=John McDonough, o=Ocean
Exploration, ou=NOAA/OAR, email=john.
mcdonough@noaa.gov, c=US
Date: 2015.02.06 15:12:01 -0500
John McDonough
Deputy Director
Office of Ocean Exploration & Research

Dated: _____

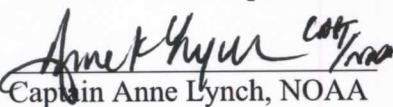
Approved by: 
Captain Anne Lynch, NOAA
Commanding Officer
Marine Operations Center - Atlantic

Dated: 2/13/2015

I. OVERVIEW

A. Cruise Period

This document contains project instructions for EX-15-02 Leg I. EX-15-02 Leg I operations are expected to commence on February 18, 2015 at North Kingstown, RI and conclude on March 11, 2015 at San Juan, Puerto Rico. Multibeam and singlebeam mapping operations will be conducted 24 hours a day throughout the cruise. Sub-bottom profile mapping will be conducted 24 hours a day at the discretion of the CO.

B. Days at Sea (DAS)

Of the 21 DAS scheduled for this project, 0 DAS are funded by an OMAO allocation, 21 DAS are funded by a Line Office Allocation. This project is estimated to exhibit a Medium Operational Tempo.

C. Operating Area

D. The transit area is in the Western Atlantic Ocean from Rhode Island straight to Puerto Rico. The general survey operating area is in the Caribbean Ocean, south Puerto Rico and St. Croix islands, in the area of Turner Hole Canyon, Saba Valley, and south of the St. Croix Ridge. The general area of the EK60 calibration will be between the islands of Isla de Culebra and Vieques. The survey of opportunity glider deployment will be east of Isla de Culebra. The first small boat transfer will be out of San Juan, Puerto Rico, and the second will be out of Charlotte Amalie, St. Thomas.

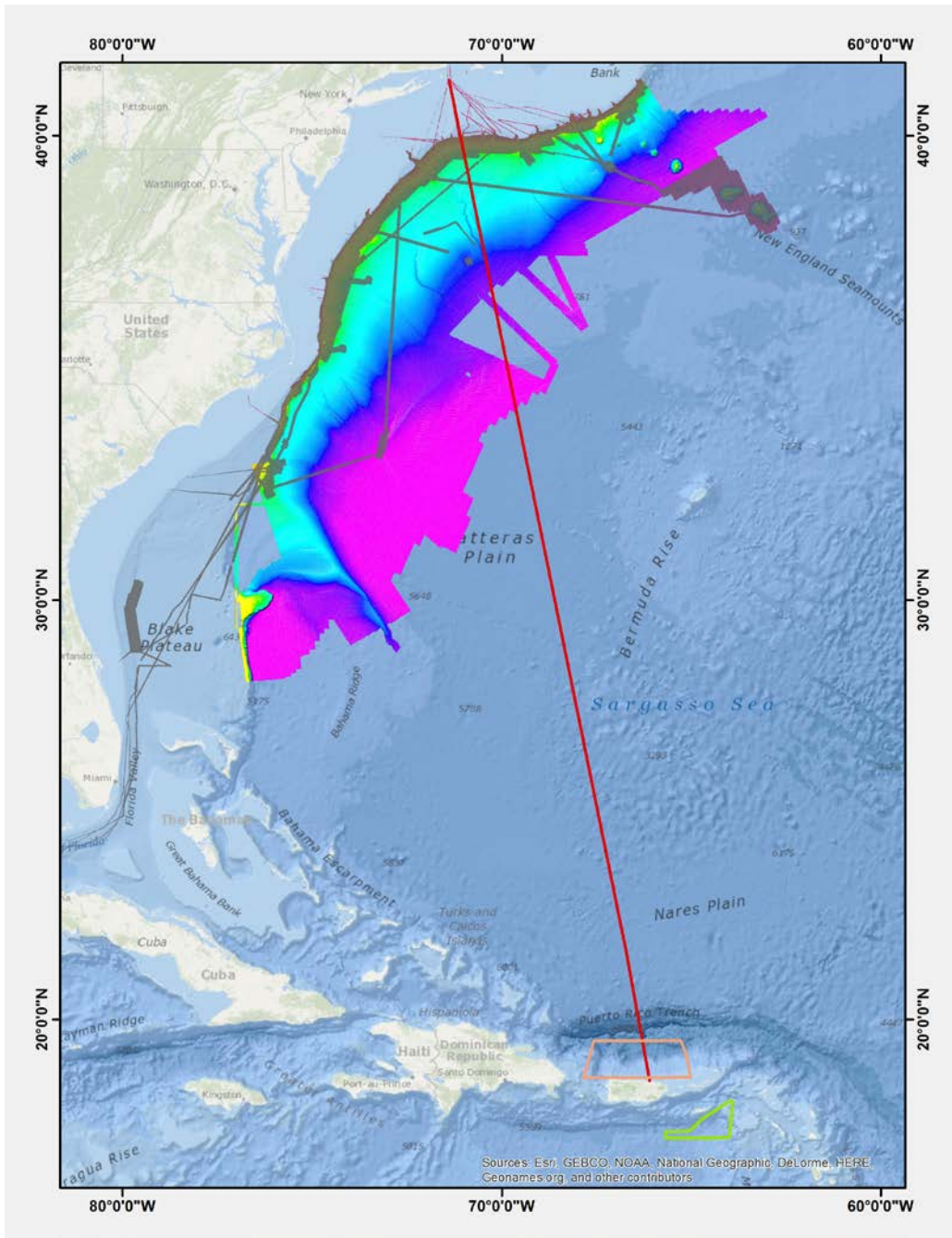

Figure 1: Transit line down to Puerto Rico (red line) and two survey area boxes. Green is the priority box, followed by the contingency plan orange box to the north. Existing available bathymetry collected by Okeanos Explorer and University of New Hampshire Law of the Sea Project shown in background, with the gray boxes showing the extent of existing EX surveys in the Atlantic.

EX-15-02 Leg I Transit Waypoints (approximate)		Remarks
71 22.2765 W	40 59.5929 N	Exit Narragansett Bay
67 17.463 W	18 48.317 N	Arrive Puerto Rico survey area
66 6.158 W	18 27.503 N	Arrive San Juan

Table 1: Approximate waypoints for the EX-15-02 Leg I transit and survey area. The actual cruise track will vary due to prevailing conditions and the discretion of the Commanding Officer.

Green Survey Area Bounding Box Coordinates		Remarks
65 40.7 W	17 11.4 N	Northwest Corner 1
65 3.4 W	17 12.3 N	Northwest Corner 2
63 56.0 W	17 57.2 N	Northeast Corner
63 59.3 W	17 2.8 N	Southeast Corner
65 41.1 W	17 1.9 N	Southwest Corner

Orange Survey Area Bounding Box Coordinates		Remarks
67 34.7 W	19 27.4 N	Northwest Corner
65 17.0 W	19 28.3 N	Northeast Corner
65 1.1 W	18 34.4 N	Southeast Corner
67 50.3 W	18 33.0 N	Southwest Corner

Table 2: Bounding box coordinates of the three survey area boxes shown in Figure 1.

E. Summary of Objectives

FEB 18 - MAR 11 2015 (North Kingstown, Rhode Island to San Juan, Puerto Rico)

During EX-15-02 Leg I, multibeam data will be collected 24 hours a day and XBT casts will be conducted at an interval defined by prevailing oceanographic conditions, but not to exceed 6 hours. Additionally, EK 60 (single beam) and sub-bottom profile data will be collected 24 hours per day. All multibeam data will be fully processed according to standard onboard procedures and will be archived with the National Geophysical Data Center. Ancillary sonar datasets will be archived at the National Oceanographic Data Center.

The EK60 single-beam sonar will be calibrated once the ship arrives in Caribbean waters. Two physical scientists from NOAA NOS will board the ship via a small boat transfer in San Juan, Puerto Rico. The anticipated date of arrival for the small boat transfer is February 26, 2015. The NOS scientists will lead the EK60 calibration, using equipment already onboard. The calibration will occur to the south of Isla de Culebra, and north of Vieques Island, see Figure 2. The calibration must occur in calm waters, so the exact location of the calibration will depend on prevailing

weather conditions. Appendix D contains the Standard Operating Procedures for conducting an EK60 calibration.

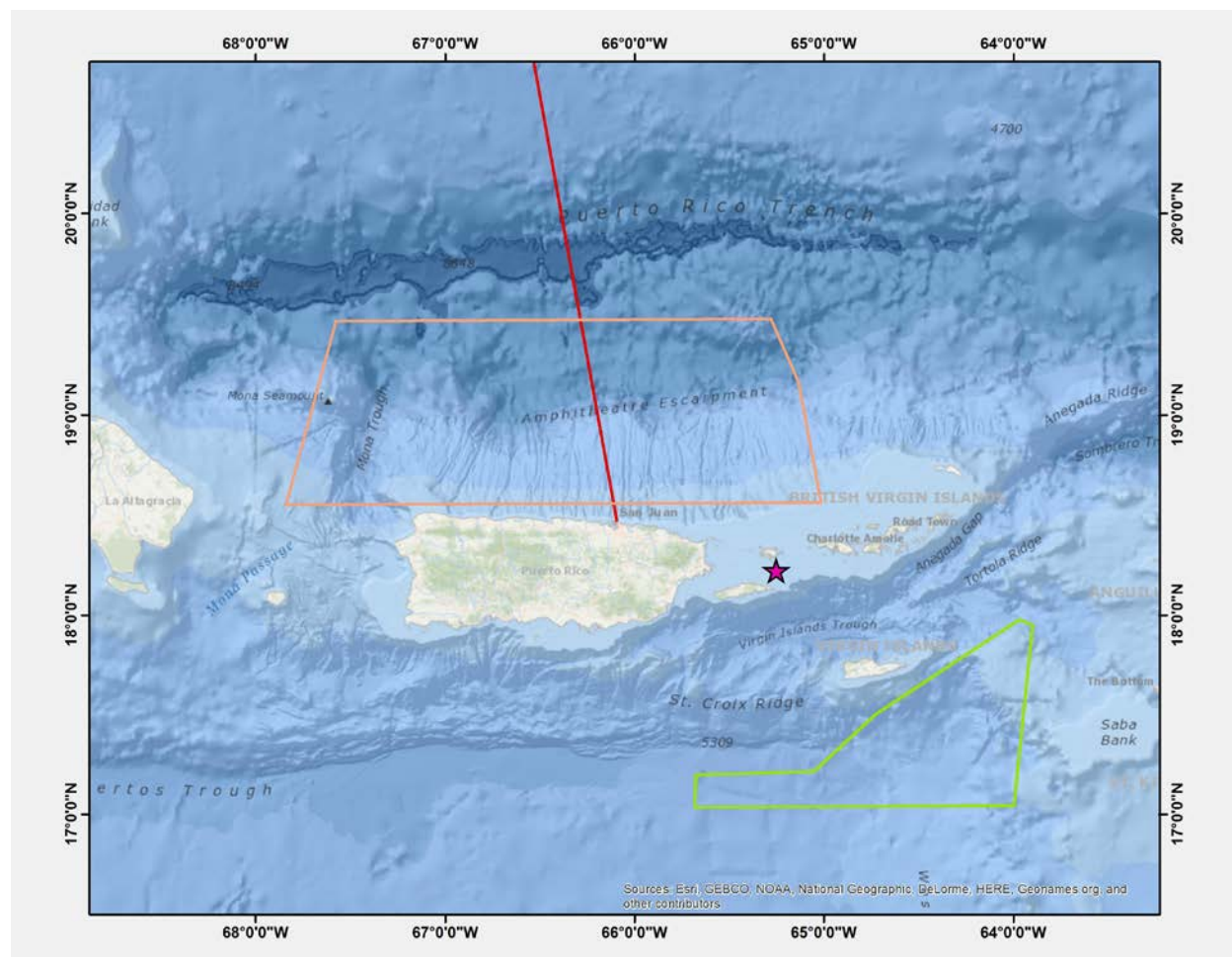

Figure 2. Approximate locations of the EK60 calibration site. The exact location of the EK60 calibration will depend of prevailing weather conditions. Survey priority boxes are also show, the green box is the top priority box.

Two survey of opportunities will be conducted during the cruise including deployment of a Slocum ocean glider and a NASA aerosols study. All survey of opportunity equipment will be loaded on the ship in North Kingstown, RI prior to departure. While the NOS scientists are onboard they will assist with deployment of the glider.

See section V and Appendix C for more detailed survey of opportunity information.

All multibeam data will be fully processed according to standard onboard procedures and will be archived with the National Geophysical Data Center. Splitbeam EK60 data will be archived at the National Oceanographic Data Center. The following are cruise objectives for EX-15-02 Leg I:

1. Collect deep water multibeam bathymetry sonar data (MBES)
 - a. Conduct 24-hour mapping operations for the duration of the cruise
 - b. Collect bathymetric, seafloor backscatter, and water column backscatter data
2. Collect ancillary sonar data
 - a. EK60 single beam sonar (24 hours/day)
 - b. Knudsen sub-bottom profiler (24 hours/day)
3. XBT operations
 - a. XBT casts will be collected at regular intervals of no more than 6 hours
4. Deploy Slocum glider
5. Conduct EK60 calibration
4. Train new personnel in all data collection and processing procedures, continuous throughout cruise)
 - a. Training of mapping watch leads new to ship
 - b. Train mapping interns (UCAR)
5. Test new or modified mission hardware and software
6. Telepresence (VSAT 5 mbps ship to shore; T1 shore to ship)
 - a. Maintain single live stream video from ship to shore

F. Participating Institutions

National Oceanic and Atmospheric Administration (NOAA) - Office of Ocean Exploration and Research (OER) - 1315 East-West Hwy, Silver Spring, MD 20910 USA

National Oceanic and Atmospheric Administration (NOAA) – National Ocean Service (NOS) - 1305 East-West Hwy, Silver Spring, MD 20910 USA

NOAA, Office of Coast Survey, Hydrographic Surveys Division, Atlantic Hydrographic Branch, 439 W. York St., Bldg 2, Norfolk, VA 23510

University of New Hampshire (UNH) Center for Coastal and Ocean Mapping (CCOM) Jere A. Chase Ocean Engineering Lab, 24 Colovos Road, Durham, NH 03824 USA

NOAA, National Oceanographic Data Center, National Coastal Data Development Center,
Stennis Space Center MS, 39529

University of Rhode Island, Graduate School of Oceanography's Inner Space Center, 215 South
Ferry Rd. Narragansett, RI 02882 USA

University Corporation for Atmospheric Research Joint Office for Science Support (JOSS), PO
Box 3000 Boulder, CO 80307 USA

G. Personnel (Science Party)

A full mapping complement is necessary for this cruise. Required mission personnel include a Mapping Lead/Expedition Coordinator as well as two qualified watchstanders for each of the three eight hour watches. The Mapping Lead is responsible for facilitating overall mapping operations, including participating in operational meetings, providing guidance for mapping/survey troubleshooting, and communicating status of mapping sensors to personnel on shore.

Name	Affiliation	Position	M/F	Status
Lindsay McKenna	NOAA OER (ERT Inc)	Expedition Coordinator/ Mapping Team Lead	F	US Citizen
James Miller	NOAA AHB	Mapping Watch Lead	M	US Citizen
David Armstrong	UCAR	Mapping Watch Lead	M	US Citizen
Josh Humberson	UCAR	Mapping Intern	M	US Citizen
Maxime Philip	UCAR	Mapping Intern	M	US Citizen
Maria Cardona Maldonado	NOAA EPP	Mapping Intern	F	US Citizen
Jennifer Johnson	UCAR	Mapping Intern	F	US Citizen
Margot Buchbinder	UCAR	Mapping Intern	F	US Citizen

Chris Taylor	NOAA NOS	EK60 Calibrator	M	US Citizen
Laura Kracker	NOAA NOS	EK60 Calibrator	F	US Citizen

Table 2: Full list of the science party members and their affiliation. Two NOAA NOS scientists will sail for 2 days, boarding and departing the ship via small boat transfer.

H. Administrative

1. Key Points of Contact:

Ship Operations

Marine Operations Center, Atlantic (MOA)
439 West York Street
Norfolk, VA 23510-1145
Telephone: (757) 441-6776
Fax: (757) 441-6495

Chief, Operations Division, Atlantic (MOA)
LCDR Donald Beaucage
Telephone: (757) 441-6842
E-mail: : ChiefOps.MOA@noaa.gov

Mission Operations

Lindsay McKenna, Expedition Coordinator/Mapping
Team Lead
NOAA Office of Ocean Exploration
and Research (ERT, Inc)
Phone : (603) 862-5246
E-mail : lindsay.mckenna@noaa.gov

CDR Mark Wetzler, NOAA
Commanding Officer
NOAA Ship *Okeanos Explorer*
Phone: Iridium - (808) 659 9179
Email: CO.Explorer@noaa.gov

LT Emily Rose, NOAA
Operations Officer
NOAA Ship *Okeanos Explorer*
Phone: (808) 659-9179
E-mail: Ops.Explorer@noaa.gov

Other Mission Contacts

John McDonough, Deputy Director
NOAA Ocean Exploration & Research
Phone: (301) 734-1023 / (240) 676-5206
E-mail: John.McDonough@noaa.gov

LT Brian Kennedy
Acting Deputy EX Program Manager
NOAA Office of Ocean Exploration
and Research
Phone : (401) 874-6150/ (706) 540-2664
E-mail : Brian.Kennedy@noaa.gov

Jared Drewniak, Telepresence Lead
NOAA Office of Ocean Exploration & Research (ERT,
Inc.)
Phone: (401) 874-6250 (o) / (401) 330-9662 (c)
Email: jared.drewniak@noaa.gov

Shipments

Send an email to the *Okeanos Explorer* Operations Officer at OPS.Explorer@noaa.gov indicating the size and number of items being shipped. All items should arrive at Davisville Depot prior to **COB February 13, 2015**.

Vessel shipping address:

ATTN: LT Emily Rose, NOAA
NOAA Ship *Okeanos Explorer*
2578 Davisville Rd.
North Kingstown, RI 02852

2. Diplomatic Clearances

None Required

3. Licenses and Permits

See Appendix B for categorical exclusion documentation

II. OPERATIONS

A. Cruise Plan Itinerary *(All times and dates are subject to prevailing conditions and the discretion of the commanding officer)*

Tuesday, February 17

- Mission personnel arrive to ship, prepare for expedition

Wednesday, February 18

- Morning departure from RI for Caribbean
- Swing compass

Thursday, February 26

- Arrive to San Juan, Puerto Rico, small boat transfer to bring NOAA NOS personnel onboard, depart for EK60 calibration area, start calibration

Friday, February 27

- Finish calibrating EK60, transit to glider deployment area, deploy glider

Saturday, February 28

- Transit to Charlotte Amalie, St. Thomas for small boat transfer

Sunday, March 1

- Transit to survey area southeast of St. Croix, begin surveying

Tuesday, March 10

- Complete surveying, transit back to San Juan

Wednesday, March 11

- Arrive at port in San Juan

Thursday, March 12

- Personnel depart ship

B. Telepresence Events

There are currently no telepresence events scheduled.

C. In-Port Events

There are currently no port events scheduled.

D. Staging and Destaging

The survey of opportunity equipment, ROV equipment, and as many boxes of XBTs that can be fit, will all be loaded on the ship while it is dockside in North Kingstown, RI. All equipment should be properly secured for a possibly rough transit to the Caribbean.

E. Sonar Operations

Multibeam, EK60, and Knudsen sub-bottom profiler data acquisition is planned for this cruise. The mapping team will ensure that all the standard protocols, as laid out by the Commanding Officer and mapping lead directives will be followed for efficient and safe mapping operations.

The final decision to operate and collect sub-bottom profiler data will be at the discretion of the Commanding Officer.

F. Applicable Restrictions

NOT APPLICABLE TO THIS CRUISE

III. EQUIPMENT

A. Equipment and capabilities provided by the ship

- Kongsberg EM302 Multibeam Echosounder (MBES)
- Kongsberg Simrad EK60 Deepwater Echosounder
- Knudsen Chirp 3260 Sub-bottom profiler (SBP)
- LHM Sippican XBT (Deep Blue probes)
- Seabird SBE 911 Plus CTD
- Seabird SBE 32 Carousel and 24 2.5 L Niskin Bottles
- Light Scattering Sensor (LSS)
- Oxidation – Reduction Potential (ORP)
- Dissolved Oxygen (DO) sensor
- Altimeter Sensor and battery pack
- CNAV GPS
- POS/MV
- Seabird SBE-45 (Micro TSG)
- Kongsberg Dynamic Positioning-1 System
- NetApps mapping storage system
- CARIS HIPS Software
- IVS Fledermaus Software
- SIS Software
- Hypack Software
- Scientific Computing System (SCS)
- ECDIS
- Met/Wx Sensor Package
- Telepresence System
- VSAT High-Speed link (Comtech 5Mbps ship to shore; 1.54 Mbps shore to ship)
- Cruise Information Management System (CIMS)

B. Equipment and capabilities provided by the scientists

- Microtops II Ozone Monitor -Sunphotometer and handheld GPS required for NASA Marine Aerosols Network supplementary project.

- Slocum glider

IV. HAZARDOUS MATERIALS

Batteries for the Slocum ocean gliders are Li-ION, which require HAZMAT precautions. The Principle Investigator (PI) for the NOS gliders project has all required NOAA Hazardous Materials documentation. The Expedition Coordinator will work with the PI to ensure all safety precautions are met.

A. Policy and Compliance

The Expedition Coordinator is responsible for complying with DMS, Fleet Environmental Compliance #07, Hazardous Material and Hazardous Waste Management Requirements for Visiting Scientists, released July 2002. Documentation regarding those requirements will be provided by the Chief of Operations, Marine Operations Center, upon request.

By Federal regulations and NOAA Marine and Aviation Operations policy, the ship may not sail without a complete inventory of all hazardous materials by name and the anticipated quantity brought aboard, MSDS and appropriate neutralizing agents, buffers, and/or absorbents in amounts adequate to address spills of a size equal to the amount of chemical brought aboard. The amount of hazardous material arriving and leaving the vessel shall be accounted for by the Expedition Coordinator.

B. Radioactive Isotopes

NOT APPLICABLE TO THIS CRUISE

C. Inventory

NOT APPLICABLE TO THIS CRUISE

V. ADDITIONAL PROJECTS

A. Supplementary Projects

The first survey of opportunity is deploying a Slocum glider that will be deployed in Caribbean water near the Virgin Island Trough, see Figure 3 for approximate location. The two NOAA NOS scientists aboard the ship for the EK60 calibration will also assist with the glider deployment. NOAA NOS personnel will depart the ship via a small boat transfer to Charlotte Amalie, St. Thomas after the glider is deployed. The glider will be recovered months later by the *NOAA Ship Nancy Foster*. More information about the deployment is included in Appendix C.

The second survey of opportunity is the NASA Maritime Aerosol Network. During the cruise the marine aerosol layer observations will be collected for the NASA Maritime Aerosol Network (MAN). Observations will be made by mission personnel (mapping interns) with a sun photometer instrument provided by the NASA MAN program. Resulting data will be delivered to the NASA MAN primary investigator Alexander Smirnov by the expedition coordinator. All collected data will be archived and publically available at: http://aeronet.gsfc.nasa.gov/new_web/maritime_aerosol_network.html. Equipment is stewarded by OER physical scientists. See Appendix C for full Survey of Opportunity Form.

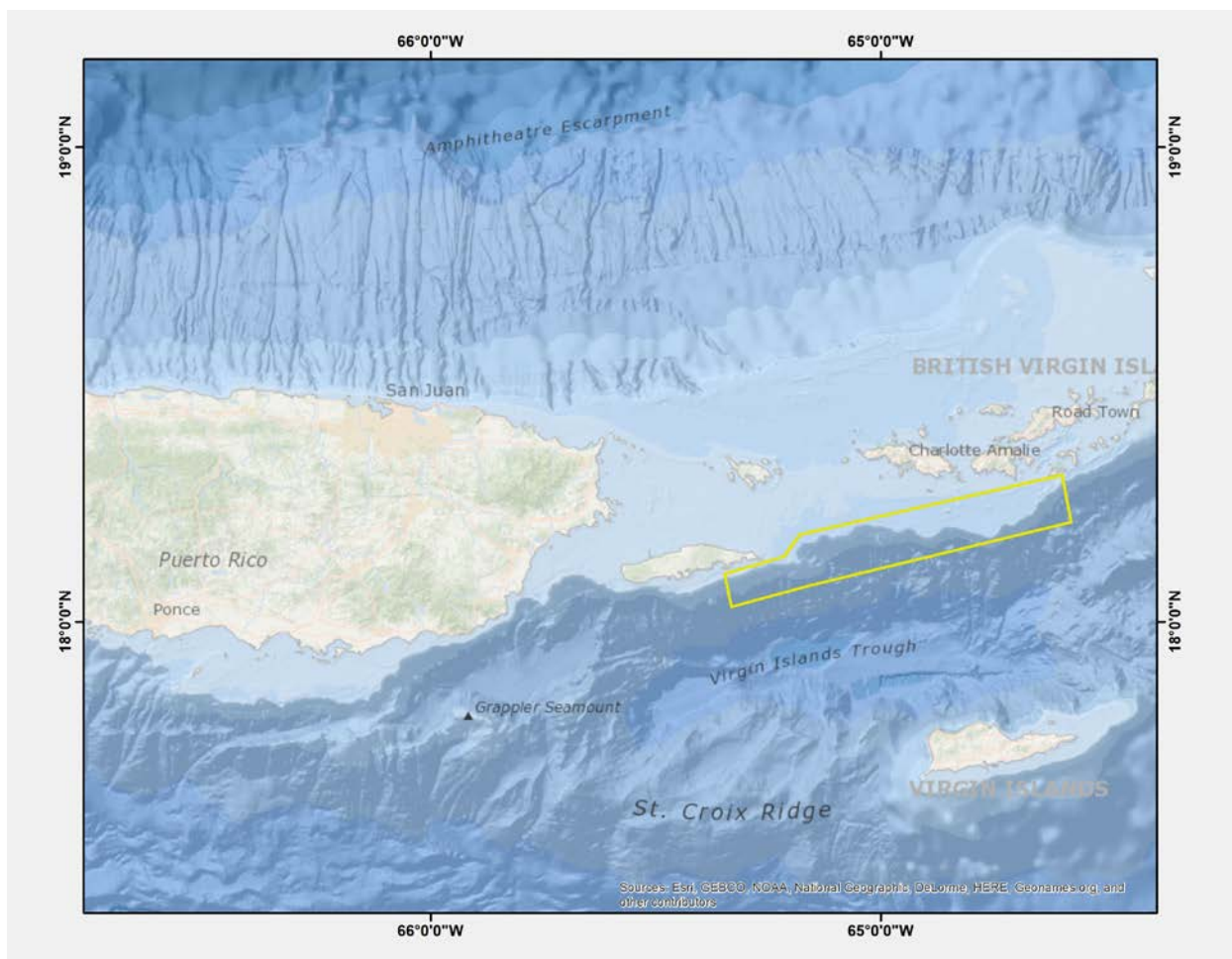

Figure 3. The general area where the glider could be deployed is outlined with a yellow box, this area is subject to change.

B. NOAA Fleet Ancillary Projects

NOT APPLICABLE TO THIS CRUISE

VI. DISPOSITION OF DATA AND REPORTS

A. Data Responsibilities

All data acquired on *Okeanos Explorer* will be provided to the public archives without proprietary rights. All data management activities shall be executed in accordance with NAO 212-15, Management of Environmental and Geospatial Data and Information [http://www.corporateservices.noaa.gov/ames/administrative_orders/chapter_212/212-15.html].

Ship Responsibilities

The Commanding Officer is responsible for all data collected for missions until those data have been transferred to mission party designees. Data transfers will be documented on NOAA Form 61-29. Reporting and sending copies of project data to NESDIS (ROSCOP form) is the responsibility of OER.

NOAA OER Responsibilities

The Expedition Coordinator will work with the *Okeanos Explorer* Operations Officer to ensure data pipeline protocols are followed for final archive of all data acquired on *Okeanos Explorer* without proprietary rights.

Deliverables

- a. At sea
 - Daily plans of the Day (POD)
 - Daily situation reports (SITREPS)
 - Daily summary bathymetry data files
- b. Post cruise
 - Refined SOPs for all pertinent operational activities
 - Assessments of all activities
- c. Science
 - Multibeam and XBT raw and processed data (see appendix B for the formal cruise data management plan)
 - EK 60 raw data
 - Knudsen 3260 sub-bottom profiler raw data
 - Mapping data report

Archive

- The Program and ship will work together to ensure documentation and stewardship of acquired data sets in accordance with NAO 212-15. The Cruise Information Management System is the primary tool used to accomplish this activity.

B. Pre and Post Cruise Meeting

Pre-Cruise Meeting

Prior to departure, the Operation's Officer will conduct a meeting of the scientific party to inform them of cruise objectives and vessel protocols, e.g., meals, watches, etiquette, etc.

Post-Cruise Meeting

Upon completion of the cruise, a meeting will be held by the Operation's Officer and attended by the ship's Survey Technicians, the Expedition Coordinator and members of the scientific party to review the cruise. Concerns regarding safety, efficiency, and suggestions for improvements for future cruises should be discussed.

Shipboard Meetings

Daily Operations Briefing meetings will be held at 1430 in the forward lounge to review the current day, and define operations, associated requirements, and staffing needs for the following day. A Plan of the Day (POD) will be posted each evening for the next day in specified locations throughout the ship. A safety brief and overview of POD will occur on the Bridge each morning at 0800. Daily Situation Reports (SITREPS) will be [emailed](#) to the EX team listserve.

C. Ship Operation Evaluation Report

Within seven days of the completion of the project, a Customer Satisfaction Survey is to be completed by the Expedition Coordinator. The form is available at <http://www.oma.noaa.gov/fleeteval.html> and provides a "Submit" button at the end of the form. Submitted form data is deposited into a spreadsheet used by OMAO management to analyze the information. Though the complete form is not shared with the ships, specific concerns and praises are followed up on while not divulging the identity of the evaluator.

VII. MISCELLANEOUS

A. Meals and Berthing

Meals and berthing are required for up to 20 scientists. Meals will be served 3 times daily beginning one hour before scheduled departure, extending throughout the cruise, and ending two hours after the termination of the cruise. Since the watch schedule is split between day and night, the night watch may often miss daytime meals and will require adequate food and beverages (for example a variety of sandwich items, cheeses, fruit, milk, juices) during what are not typically meal hours. Special dietary requirements for scientific participants will be made available to the ship's command at least twenty-one days prior to the survey (e.g., Expedition Coordinator is allergic to fin fish). Berthing requirements, including number and gender of the scientific party, will be provided to the ship by the Expedition Coordinator. The Expedition Coordinator and Operations Officer will work together on a detailed berthing plan to accommodate the gender mix

of the scientific party taking into consideration the current make-up of the ship's complement. The Expedition Coordinator is responsible for ensuring the scientific berthing spaces are left in the condition in which they were received; for stripping bedding and linen return; and for the return of any room keys which were issued. The Expedition Coordinator is also responsible for the cleanliness of the laboratory spaces and the storage areas utilized by the scientific party, both during the cruise and at its conclusion prior to departing the ship.

All NOAA scientists will have proper travel orders when assigned to any NOAA ship. The Expedition Coordinator will ensure that all non NOAA or non-Federal scientists aboard also have proper orders. It is the responsibility of the Expedition Coordinator to ensure that the entire scientific party has a mechanism in place to provide lodging and food and to be reimbursed for these costs in the event that the ship becomes uninhabitable and/or the galley is closed during any part of the scheduled project.

All persons boarding NOAA vessels give implied consent to comply with all safety and security policies and regulations which are administered by the Commanding Officer. All spaces and equipment on the vessel are subject to inspection or search at any time. All personnel must comply with OMAO's Drug and Alcohol Policy dated May 7, 1999 which forbids the possession and/or use of illegal drugs and alcohol aboard NOAA Vessels.

B. Medical Forms and Emergency Contacts

The NOAA Health Services Questionnaire (NHSQ, NF 57-10-01 (3-14)) must be completed in advance by each participating scientist. The NHSQ can be obtained from the Chief Scientist or the NOAA website

<http://www.corporateservices.noaa.gov/noaaforms/eforms/nf57-10-01.pdf>.

All NHSQs submitted after March 1, 2014 must be accompanied by [NOAA Form \(NF\) 57-10-02](#) - Tuberculosis Screening Document in compliance with [OMAO Policy 1008](#) (Tuberculosis Protection Program).

The completed forms should be sent to the Regional Director of Health Services at the applicable Marine Operations Center. The NHSQ and Tuberculosis Screening Document should reach the Health Services Office no later than 4 weeks prior to the start of the project to allow time for the participant to obtain and submit additional information should health services require it, before clearance to sail can be granted. Please contact MOC Health Services with any questions regarding eligibility or completion of either form. Ensure to fully complete each form and indicate the ship or ships the participant will be sailing on. The participant will receive an email notice when medically cleared to sail if a legible email address is provided on the NHSQ.

The participant can mail, fax, or email the forms to the contact information below.

Participants should take precautions to protect their Personally Identifiable Information (PII) and medical information and ensure all correspondence adheres to DOC guidance (http://ocio.os.doc.gov/ITPolicyandPrograms/IT_Privacy/PROD01_008240).

The only secure email process approved by NOAA is [Accellion Secure File Transfer](#)

which requires the sender to setup an account. [Accellion's Web Users Guide](#) is a valuable aid in using this service, however to reduce cost the DOC contract doesn't provide for automatically issuing full functioning accounts. To receive access to a "Send Tab", after your Accellion account has been established send an email from the associated email account to accellionAlerts@doc.gov requesting access to the "Send Tab" function. They will notify you via email usually within 1 business day of your approval. The "Send Tab" function will be accessible for 30 days.

Contact information: **Include only the Pacific OR Atlantic Office as applicable.**

Regional Director of Health Services
Marine Operations Center – Atlantic
439 W. York Street
Norfolk, VA 23510
Telephone 757-441-6320
Fax 757-441-3760
Email MOA.Health.Services@noaa.gov

Regional Director of Health Services
Marine Operations Center – Pacific
2002 SE Marine Science Dr.
Newport, OR 97365
Telephone 541-867-8822
Fax 541-867-8856
Email MOP.Health-Services@noaa.gov

C. Shipboard Safety

Wearing open-toed footwear or shoes that do not completely enclose the foot (such as sandals or clogs) outside of private berthing areas is not permitted. Steel-toed shoes are required to participate in any work dealing with suspended loads, including CTD deployments and recovery. The ship does not provide steel-toed boots. Hard hats are also required when working with suspended loads. Work vests are required when working near open railings and during small boat launch and recovery operations. Hard hats and work vests will be provided by the ship when required.

Operational Risk Management: For every operation to be conducted aboard the ship (NOAA-wide initiative), risk management procedures will be followed. For each operation, risks will be identified and assessed for probability and severity. Risk mitigation strategies / measures will be investigated and implemented where possible. After mitigation, the residual risk will have to be assessed to make Go-No Go decisions for the operations. Particularly with new operations, risk assessment will be ongoing and updated as necessary. This does not only apply to over-the-side operations, but to everyday tasks aboard the vessel that pose risk to personnel and property.

- CTD, ROV (and other pertinent) ORM documents will be followed by all personnel working on board *Okeanos Explorer*.
- All personnel on board are in the position of calling a halt to operations/activities in the event of a safety concern.

D. Communications

A daily situation report (SITREP) on operations prepared by the Expedition Coordinator will be relayed to the program office. Sometimes it is necessary for the Expedition Coordinator to communicate with another vessel, aircraft, or shore facility. Through various modes of communication, the ship is able to maintain contact with the Marine Operations Center on an as needed basis. These methods will be made available to the Expedition Coordinator upon request, in order to conduct official business. The ship's primary means of communication with the Marine Operations Center is via e-mail and the Very Small Aperture Terminal (VSAT) link. Standard VSAT bandwidth at 128kbs is shared by all vessels staff and the science team at no charge. Increased bandwidth in 30 day increments is available on the VSAT systems at increased cost to the scientific party. If increased bandwidth is being considered, program accounting is required it must be arranged at least 30 days in advance.

Specific information on how to contact NOAA Ship *Okeanos Explorer* and all other fleet vessels can be found at <http://www.moc.noaa.gov/MOC/phone.html#EX>
Important Telephone and Facsimile Numbers and E-mail Addresses

Ocean Exploration and Research (OER):

OER Program Administration:

Phone: (301) 734-1010

Fax: (301) 713-4252

E-mail: Firstname.Lastname@noaa.gov

University of New Hampshire, Center for Coastal and Ocean Mapping

Phone: (603) 862-3438

Fax: (603) 862-0839

NOAA Ship *Okeanos Explorer* - Telephone methods listed in order of increasing expense:

Okeanos Explorer Cellular: (401) 713-4114

Okeanos Explorer Iridium: (808) 659-9179

OER Mission Iridium (dry lab): (808) 851-3827

EX INMARSAT B

Line 1: 011-870-764-852-328

Line 2: 011-870-764-852-329

Voice Over IP (VoIP) Phone:

301-713-7772 (expect a delay once picked up by directory)

E-Mail: Ops.Explorer@noaa.gov - (mention the person's name in SUBJECT field)

expeditioncoordinator.explorer@noaa.gov - For dissemination of all hands emails by Expedition Coordinator while on board. See ET for password.

E. IT Security

Any computer that will be hooked into the ship's network must comply with the NMAO Fleet IT Security Policy prior to establishing a direct connection to the NOAA WAN. Requirements include, but are not limited to:

1. Installation of the latest virus definition (.DAT) file on all systems and performance of a virus scan on each system.
2. Installation of the latest critical operating system security patches.
3. No external public Internet Service Provider (ISP) connections.

Completion of these requirements prior to boarding the ship is required.

Non-NOAA personnel using the ship's computers or connecting their own computers to the ship's network must complete NOAA's IT Security Awareness Course within 3 days of embarking.

F. Foreign National Guests Access to OMAO Facilities and Platforms

All foreign national access to the vessel shall be in accordance with [NAO 207-12](#) and [RADM De Bow's March 16, 2006 memo](#).

The following are basic requirements. Full compliance with [NAO 207-12](#) is required.

Responsibilities of the Expedition Coordinator:

1. Provide the Commanding Officer with the e-mail generated by the FRNS granting approval for the foreign national guest's visit. This e-mail will identify the guest's DSN and will serve as evidence that the requirements of [NAO 207-12](#) have been complied with.
2. Escorts – The Expedition Coordinator is responsible to provide escorts to comply with [NAO 207-12](#) Section 5.10, or as required by the vessel's DOC/OSY Regional Security Officer. Ensure all non-foreign national members of the scientific party receive the briefing on Espionage Indicators ([NAO 207-12](#)) at least annually or as required by the servicing Regional Security Officer.
3. Export Control - The NEFSC currently neither possesses nor utilizes technologies that are subject to Export Administration Regulations (EAR).

The Commanding Officer and the Expedition Coordinator will work together to implement any access controls necessary to ensure no unlicensed export occurs of any controlled technology onboard regardless of ownership.

Responsibilities of the Commanding Officer:

1. Ensure only those foreign nationals with DOC/OSY clearance are granted access.

2. Deny access to OMAO platforms and facilities by foreign nationals from countries controlled for anti-terrorism (AT) reasons and individuals from Cuba or Iran without written NMAO approval and compliance with export and sanction regulations.
3. Ensure foreign national access is permitted only if unlicensed deemed export is not likely to occur.
4. Ensure receipt from the Expedition Coordinator or the DSN of the FRNS e-mail granting approval for the foreign national guest's visit.
5. Ensure Foreign Port Officials, e.g., Pilots, immigration officials, receive escorted access in accordance with maritime custom to facilitate the vessel's visit to foreign ports.
6. Export Control - 8 weeks in advance of the cruise, provide the Expedition Coordinator with a current inventory of OMAO controlled technology onboard the vessel and a copy of the vessel Technology Access Control Plan (TACP). Also notify the Expedition Coordinator of any OMAO-sponsored foreign nationals that will be onboard while program equipment is aboard so that the Expedition Coordinator can take steps to prevent unlicensed export of Program controlled technology. The Commanding Officer and the Expedition Coordinator will work together to implement any access controls necessary to ensure no unlicensed export occurs of any controlled technology onboard regardless of ownership.
7. Ensure all OMAO personnel onboard receive the briefing on Espionage Indicators [NAO 207-12](#)) at least annually or as required by the servicing Regional Security Officer.

Responsibilities of the Foreign National Sponsor:

1. Export Control - The foreign national's sponsor is responsible for obtaining any required export licenses and complying with any conditions of those licenses prior to the foreign national being provided access to the controlled technology onboard regardless of the technology's ownership.
2. The DSN of the foreign national shall assign an on-board Program individual, who will be responsible for the foreign national while on board. The identified individual must be a U.S. citizen, NOAA (or DOC) employee. According to DOC/OSY, this requirement cannot be altered.
3. Ensure completion and submission of the Certification of Conditions and Responsibilities for a Foreign National Guest as required by [NAO 207-12](#) Section 5.03.h.

Appendix A. Data Management Plan

Data Management Plan

Okeanos Explorer (EX1502L1): Caribbean Exploration (Mapping)



OER Data Management Objectives

Ensure consolidation of standard sensor and mapping products; Ensure ship to shore data synchronization between shipboard and shoreside repositories; Ensure generation and shoreside display of dashboard datasets

05-Feb-15

Page 1

1. General Description of Data to be Managed

1.1 Name and Purpose of the Data Collection Project

Okeanos Explorer (EX1502L1): Caribbean Exploration (Mapping)

1.2 Summary description of the data to be collected.

During the transit, multibeam data will be collected 24 hours a day and XBT casts will be conducted no less than every 6 hours. Singlebeam (EK60) data and sub-bottom profile data will be also collected 24 hours a day.

1.3 Keywords or phrases that could be used to enable users to find the data.

expedition, exploration, explorer, marine education, noaa, ocean, ocean discovery, ocean education, ocean exploration, ocean exploration and research, ocean literacy, ocean research, OER, science, scientific mission, scientific research, sea, stewardship, systematic exploration, technology, transformational research, undersea, underwater, Davisville, mapping survey, multibeam, multibeam backscatter, multibeam sonar, multi-beam sonar, noaa fleet, okeanos, okeanos explorer, R337, Rhode Island, scientific computing system, SCS, single beam sonar, singlebeam sonar, single-beam sonar, sub-bottom profile, water column backscatter, Puerto Rico Trench, St Croix Ridge, Turner Hole Canyon, Saba Valley, Puerto Rico Shelf, Isla de Culebra, Muertos Trough, glider, maritime aerosol network, NAVOCEANO glider

1.4 If this mission is part of a series of missions, what is the series name?

Okeanos Mapping Cruises

1.5 Planned or actual temporal coverage of the data.

Dates: 2/18/2015 to 3/11/2015

1.6 Planned or actual geographic coverage of the data.

Latitude Boundaries: 41 to 17

Longitude Boundaries: -71.5 to -63

1.7 What data types will you be creating or capturing and submitting for archive?

Cruise Plan, Cruise Summary, Data Management Plan, Highlight Images, Quick Look Report, EK60 Singlebeam Data, Bottom Backscatter, Floating Point GeoTIF, GSF, Mapping Summary, NetCDF, Multibeam (raw), Multibeam (processed), Multibeam (image), Multibeam (product), SCS Output (compressed), SCS Output (native), Sub-Bottom Profile data, Water Column Backscatter, XBT (raw)

1.8 What platforms will be employed during this mission?

Okeanos Explorer (EX1502L1): Caribbean Exploration (Mapping)

NOAA Ship Okeanos Explorer, Glider

2. Point of Contact for this Data Producing Project

Overall POC: Lindsay McKenna, Physical Scientist, NOAA Office of Ocean Exploration and Research, Lindsay.M
 Title: Expedition Coordinator, Mapping Lead
 Affiliation/Dept: NOAA OER; University of New Hampshire, Center for Coastal and Ocean Mapping, Joint Hydrogr
 E-Mail: lindsay.mckenna@noaa.gov
 Phone: 609-862-5246

3. Point of Contact for Managing the Data

Data POC Name: Susan Gottfried, Data Management Coordinator, NOAA National Coastal Data Development Ce
 Title: NOAA/NCEI, Senior Scientist, General Dynamics Information Technology
 E-Mail: susan.gottfried@noaa.gov

4. Resources

- 4.1 Have resources for management of these data been identified? True
- 4.2 Approximate percentage of the budget devoted to data management. (specify % or "unknown")
 unknown

5. Data Lineage and Quality

5.1 What is the processing workflow from collection to public release?

SCS data shall be delivered in its native format as well as an archive-ready, documented, and compressed NetCDF-3 format to NODC; multibeam data and metadata will be compressed and delivered in a bagit format to NGDC.

5.2 What quality control procedures will be employed?

Quality control procedures for the data from the Kongsberg EM302 is handled at UNH CCOM/JHC. Raw (level-0) bathymetry files are cleaned/edited into new data files (level-1) and converted to a variety of products (level-2). Data from sensors monitored through the SCS are archived in their native format and are not quality controlled. Data from CTD casts and XBT firings are archived in their native format and are not quality controlled. CTDs are processed into profiles for display only on the Okeanos Atlas.

6. Data Documentation

6.1 Does the metadata comply with the Data Documentation Directive? True

6.1.1 If metadata are non-existent or non-compliant, please explain:

not applicable

6.2 Where will the metadata be hosted?

Organization: An ISO format collection-level metadata record will be generated during pre-cruise planning
 URL: www.ncddc.noaa.gov/oer-waf/
 discovery and access. The record will be harvested by data.gov.

Meta Std: ISO 19115-2 Geographic Information with Extensions for Imagery and Gridded Data will be the metadata standard employed; a NetCDF-4 standard for oceanographic data will be employed for the SCS data; the Library of Congress standard, MACHine Readable Catalog (MARC), will be employed for NOAA Central Library records.

6.3 Process for producing and maintaining metadata:

Metadata will be generated via xml editors or metadata generation tools.

7. Data Access

7.1 Do the data comply with the Data Access Directive?

True

7.1.1 If the data are not to be made available to the public at all, or with limitations, provide a valid reason.

Not Applicable

7.1.2 If there are limitations to public data access, describe how data are protected from unauthorized access or disclosure.

Account access to mission systems are maintained and controlled by the Program. Data access prior to public accessibility is documented through the use of Data Request forms and standard operating procedures.

7.2 Name and URL of organization or facility providing data access.

Org: NOAA National Centers for Environmental Intelligence

URL: explore.noaa.gov/digitalatlas

7.3 Approximate delay between data collection and dissemination. By what authority?

Hold Time: not applicable

Authority: not applicable

7.4 Prepare a Data Access Statement

No data access constraints, unless data are protected under the National Historic Preservation Act of 1966.

8. Data Preservation and Protection

8.1 Actual or planned long-term data archive location:

Data from this mission will be preserved and stewarded through the NOAA National Centers for Environmental Intelligence. Refer to the Okeanos Explorer FY15 Data Management Plan at NOAA's EDMC DMP Repository (EX_FY15_DMP_Final.pdf)

8.2 If no archive planned, why?

not applicable

8.3 If any delay between data collection and submission to an archive facility, please explain.

60-90 days

8.4 How will data be protected from accidental or malicious modification or deletion?

Data management standard operating procedures minimizing accidental or malicious modification or deletion are in place aboard the Okeanos Explorer and will be enforced.

8.5 Prepare a Data Use Statement

Data use shall be credited to NOAA Office of Ocean Exploration and Research.

Okeanos Explorer (EX1502L1): Caribbean Exploration (Mapping)

Appendix B. Categorical Exclusion



UNITED STATES DEPARTMENT OF COMMERCE
National Oceanic and Atmospheric Administration
OCEANIC AND ATMOSPHERIC RESEARCH
Office of Ocean Exploration and Research
Silver Spring, MD 20910

January 7, 2015

MEMORANDUM FOR: The Record

FROM: John McDonough
Acting Director NOAA Office of Ocean Exploration
and Research (OER)

SUBJECT: Categorical Exclusion for NOAA Ship *Okeanos Explorer*
Cruise EX-15-02 Leg 1 and Leg 2

NAO 216-6, Environmental Review Procedures, requires all proposed projects to be reviewed with respect to environmental consequences on the human environment. This memorandum addresses the NOAA Ship *Okeanos Explorer's* scientific sensors possible effect on the human environment.

This project is part of the NOAA Office of Ocean Exploration and Research's "Science Program" and entails multi-disciplinary ocean mapping and exploration activities designed to increase knowledge of the marine environment. This project is entitled "EX-15-02 Legs 1 and 2 Exploration, Caribbean (Mapping)" and will be led by Lindsay McKenna (Leg 1), and Elizabeth Lobecker (Leg 2), both Physical Scientists for the *Okeanos Explorer* program within OER. NOAA Ship *Okeanos Explorer* will depart North Kingstown, RI for Leg 1 on February 18, 2015, and arrive in port in San Juan, Puerto Rico on March 11, 2015. Leg 2 will depart San Juan, Puerto Rico on March 16, 2015 and arrive in port in San Juan, Puerto Rico on April 3, 2015. NOAA Ship *Okeanos Explorer* will conduct sonar mapping operations at all times during the cruise. Focused mapping and sonar testing operations will occur along a transit path from Rhode Island to Puerto Rico, then within top priority exploration target areas in U.S. federal waters around Puerto Rico and St. Croix islands. Acoustic instruments that will be operational during the project are a 30 kHz multibeam echosounder (Kongsberg EM 302), an 18 kHz singlebeam echosounder (Kongsberg EK 60), and a 3.5 kHz sub-bottom profiler (Knudsen Chirp 3260). Additionally, expendable bathythermographs (XBTs) will be deployed at regular intervals in association with multibeam data collection.



As expected for ocean research with limited duration or presence in the marine environment, this project will not have the potential for significant impacts. Knowledgeable experts who are aware of the sensitivities of the marine environment will conduct the at-sea portions of this project.

This project would not result in any changes to the human environment. As defined in Sections 5.05 and 6.03.c.3 (a) of NAO 216-6, this is a research project of limited size or magnitude or with only short-term effects on the environment and for which any cumulative effects are negligible. As such, this project is categorically excluded from the need to prepare an environmental assessment.

Appendix C. Survey of Opportunities

Slocum Gliders Survey of Opportunity

SURVEYS OF OPPORTUNITY - INITIAL REQUEST FORM

A surveys of opportunity is a small, exploratory expedition that takes advantage of the elastic schedules of ocean-going, research vessels, - in this case, the Okeanos Explorer - by maximizing transit times between ports or projects, or by filling small gaps in the ship’s calendar.

Given the ship’s unique technology and capabilities, NOAA’s Office of Ocean Exploration and Research (OER) invites regional researchers to help acquire additional data within the vessel’s operating areas to assess specific but poorly known sites, adding to an inventory of submerged resources. In circumstances where individuals cannot serve on a “survey of opportunity”, then OER ensures that acquired data and any other pertinent information are transferred to the appropriate researchers after the expedition. Previously successful surveys of opportunity have included mapping geological features, locating and characterizing shipwrecks, and defining marine protected areas. Some surveys are completed in only a few hours, while others last a couple days.

Although exploration potential and scientific merit play a role in which opportunistic surveys are conducted, they are not chosen through a peer-reviewed process. Rather, their selection is based more on the vessel operating in the right place with the right equipment at the right time, and the ship’s calendar and on-board resources allow for the added work. All requests for a survey of opportunity are archived with OER and the ship, and expire only when the survey work is completed. There is no guarantee that any request for a survey will be accomplished, nor is there any system of prioritization or ranking. Keep in mind that this proposal may be available to the public upon request except for privileged information and material that is personal, proprietary or otherwise exempt from disclosure under law.

Survey or Project Name

Providing oceanographic and bioacoustic data from ocean glider missions in the US Caribbean

Points of Contact (POC)

<i>Lead POC or Principle Investigator (PI & Affiliation)</i> Tim Battista, NOS/NCCOS/CCMA	<i>Supporting Team Members</i> Chris Taylor, NOS/NCCOS/CCFHR
---	--

Activities Description(s) *(Include goals, objectives and tasks)*

NCCOS has partnered with the US Navy Oceanographic Office to conduct glider missions in the US Caribbean in 2015. The goal of the mission is to use the gliders to traverse insular shelf waters and record oceanographic conditions that will provide data to assimilative oceanographic current models in the region. The PIs will also attach a passive acoustic recorder to the gliders to record ambient noise such as sounds made by fish and marine mammals as well as anthropogenic sounds from ships and other sources. The preferred working area for the glider mission is the north insular shelf of St. Thomas, USVI, southeast Puerto Rican insular shelf south of St. Thomas, USVI and St. Croix, USVI.

The mission is planned for Spring 2015 during a time when the NOAA Ship Nancy Foster will be in the region conducting seafloor mapping, ecosystem characterization and oceanographic studies (mid-March - mid-April). To further extend and maximize the glider mission duration in the US Caribbean region, the PIs request the use of the Okeanos Explorer to deploy one or two gliders in waters off Puerto Rico or US Virgin Islands.

List of Participating Organizations

NOS NCCOS
 Naval Oceanographic Office, Glider Operations Center

Duration (specific start and end dates, or expected length of survey)

Deployment of glider would commence upon Okeanos Explorer arrival to working grounds east and northeast of main island of Puerto Rico, Culebra, or the US Virgin Islands. Once deployment and commenced by US Navy Glider Operations Center, the ship will not be needed unless it is determined that the glider has malfunctioned and requires retrieval.
 Glider retrieval will be conducted using the NOAA Ship Nancy Foster in early or mid-April.

Area of Survey and Cruise Track Descriptions (please attach appropriate charts and include chart reference numbers)

Preferred working area for the glider is the northern and/or southern insular shelf of St. Thomas, USVI.

Conditions and Dependencies (e.g, water depths, special sea conditions, time constraints, etc)

Refer to glider deployment and retrieval standard operating procedures provided by NOAA Ship Nancy Foster.

Equipment/Systems Needed

<input checked="" type="checkbox"/> DP <input type="checkbox"/> A-Frame <input type="checkbox"/> Traction Winch <input type="checkbox"/> Hydro Winch <input type="checkbox"/> ROV Crane <input type="checkbox"/> General Purpose Crane <input type="checkbox"/> EM302 <input type="checkbox"/> Deep Water Echo Sounder <input type="checkbox"/> VSAT Pipe Mbps # days full pipe <input type="checkbox"/> Cameras <input type="checkbox"/> Telepresence <input type="checkbox"/> CCTV <input type="checkbox"/> ROV	<input type="checkbox"/> Sled <input type="checkbox"/> xBot <input type="checkbox"/> Seawater flow-through system <input type="checkbox"/> Fluorometer <input type="checkbox"/> CTD (deck unit) <input type="checkbox"/> CTD Rosette <input type="checkbox"/> SCS Outputs <input type="checkbox"/> Hazardous Storage Describe: <input checked="" type="checkbox"/> Other ship's equipment(s): Describe All: Small boats if needed to monitor glider during initial stage of deployment
--	--

Special Equipment (identify any PI-supplied gear that the ship will be requested to deploy)

US Navy Owned Slocum Ocean Gliders (two vehicles)
 NCCOS owned passive acoustic recorder (Remora-ST) to be programmed and attached to the glider prior to deployment.

Lead Time and Long Lead Time Items (e.g., permits, etc)

NA

Shore-side support (besides staffing, what other coordination is needed, e.g. telepresence center)

None

Data, Products and Outputs (requested shipboard data processing, archiving and product generation, such as sonar processing, GIS layer creation, mosaic, video archiving, etc)

SCS records at time of glider deployment

QUALITATIVE PARAMETERS

Why is this project considered “exploration”?

The use of ocean gliders extends the exploration capabilities of the NOAA research fleet by surveying, exploring and providing near real-time oceanographic observations in poorly studied regions of the US Caribbean. The attached passive acoustic recorders will also provide unique sensor-level data on the bioacoustic properties of the US Caribbean, with a particular focus on identifying a locating reef fish spawning aggregations for grouper species and other fishes.

How is this survey multidisciplinary? (Will various types of data be acquired by different user groups during the survey? Will the data products will be used by different users after the survey?)

The glider mission will collect a suite of data streams of use to multiple disciplines. First, the US Caribbean ocean circulation is poorly derived for regions near the islands. Oceanographic conditions throughout the watercolumn using the glider will fill important gaps. The bioacoustic properties of the ocean are of particular interest to fisheries managers charged with managing and conserving reef fish populations.

What is the public outreach potential for this project?

NCCOS and the Navy conducted a similar glider mission in 2014. While a technical failure in the glider shortened the mission, both the NCCOS News site and the US Virgin Islands Newspaper covered the glider mission and resulted in several contacts between members of the general public and scientists in the US Caribbean. <http://virginislandsdailynews.com/news/noaa-scientists-eavesdrop-on-sex-lives-of-fish-1.1651338>

What will become of the data, imagery, information and samples after this survey?
(Who is responsible for data archiving? How will the information be archived? Are there any intended publications from this survey? Will this data be used as leverage for follow-up investigation?)

The PIs intend to make the bioacoustic recordings data public following analysis for target sounds made by reef fishes. NCCOS is consulting NOAA Data Centers on methods for archiving the raw bioacoustic data.

What restrictions of confidentiality are placed on this request? *(Can this request be shared with OER partners operating in the area who might be able to acquire these data? Is any part of this intended dataset sensitive and restricted? Are you willing to work with NOAA public affairs officials to report any discoveries made by this survey?)*

None

If this project is maritime archeologically-focused, what is the site's archaeological or historical importance?

NA

If this project is maritime archeologically-focused, who has jurisdiction over the site, and have the appropriate agencies been contacted?

NA

NASA Maritime Aerosols Network Survey of Opportunity

Survey or Project Name

Maritime Aerosol Network

Points of Contact (POC)

<i>Lead POC or Principle Investigator (PI & Affiliation)</i>	<i>Supporting Team Members ashore</i>
POC: Dr. Alexander Smirnov	<i>Supporting Team Members aboard (if required)</i>

Activities Description(s) *(Include goals, objectives and tasks)*

The Maritime Aerosol Network (MAN) component of AERONET provides ship-borne aerosol optical depth measurements from the Microtops II sun photometers. These data provide an alternative to observations from islands as well as establish validation points for satellite and aerosol transport models. Since 2004, these instruments have been deployed periodically on ships of opportunity and research vessels to monitor aerosol properties over the World Oceans.

Reference (a): Glider Functional Checkout Procedure, Teledyne Webb Research,
Document #4095, Revision A, 13 Apr 2011

(b): NAVOCEANO Glider Operations Phone Number and email address -
228-688-5877, gliders@ocean.navy.mil

Tools and Equipment

Glider Cart
Green Go Plug
Float Release Mechanism
Docking Cone Assembly

Safety Considerations

The glider contains a Lithium Primary Battery Pack. If the glider is damaged by the ship or pulled through the screw, the glider will most likely be damaged to the point that the water tight integrity of the hull will be compromised. In this case a very careful assessment must be made before bringing the glider back onboard. Any severe physical damage to the glider will most likely rupture the pressure housing causing it to sink. A small leak would be very unlikely, but could allow seawater into the pressure housing and cause a violent reaction with the battery pack. In this event, the glider hull is designed to separate, which will vent pressure and gasses generated by a battery reaction to the atmosphere to the port side of the glider. This will be evident by an intermittent hissing sound or bubbles being discharged into the water. In this case, it is recommended that the glider be scuttled (e.g. using small arms fire or any other means).

If the glider is dropped from 3 feet or more, or is jolted in a similar fashion from any angle, a check of the internal vacuum sensor and battery pack voltage should be accomplished per the guidance provided in reference (a) to verify the integrity of the battery packs. A visual inspection of the hull should then be completed to verify that hull water integrity is still intact.

General Notes

- The desired glider launch setup is to employ an aft U-frame on the ship while the ship is moving no more than one knot through the water in a forward direction. This setup presents less risk of the ship and glider colliding during and after launch, and less risk of the glider being pulled through the ship's screws.
- Before picking up the glider cart for launch roll the wheels of the cart off the edge of the ship. This will ensure the nose of the glider does not drag on the deck of the ship and prevent damage to the glider. Damage to the nose of the glider will make it inoperable. Also fully submerge the glider cart during launch to prevent cart entanglement with the glider after separation.

- A primary factor that must be considered during glider launch operations is whether sea state conditions are within acceptable limitations. Typically, these operations have been successfully conducted in up to 6 ft seas from the T-AGS ships.
- There are two methods of communications for the glider - Freewave and Iridium. While the Freewave is being used locally, it will override the Iridium (at least until no commands are received via Freewave).
- A Functional Check, as found in reference (a), should be completed upon receipt of the glider on board ship to verify that no damage occurred during shipping (and to allow time for the glider's Global Positioning System (GPS) to build an almanac for the current area).

General Specifications

Weight in air: 59kg

Diameter: 22 cm

Length: 1.5 m

Glider Launch Sequence

- Arrange a launch time with the NAVOCEANO Glider Operations Center (GOC) at least one week in advance via reference (b). Call GOC 24 hours before launching to verify launch time. Then call one hour before the ship will be on station for the launch.
- Login and setup laptop with USB to serial converter and Freewave modem.
- Attach the Float Release Mechanism to the glider cart. Attach Docking Cone Assembly to the glider cart using the 4 quick release pins.

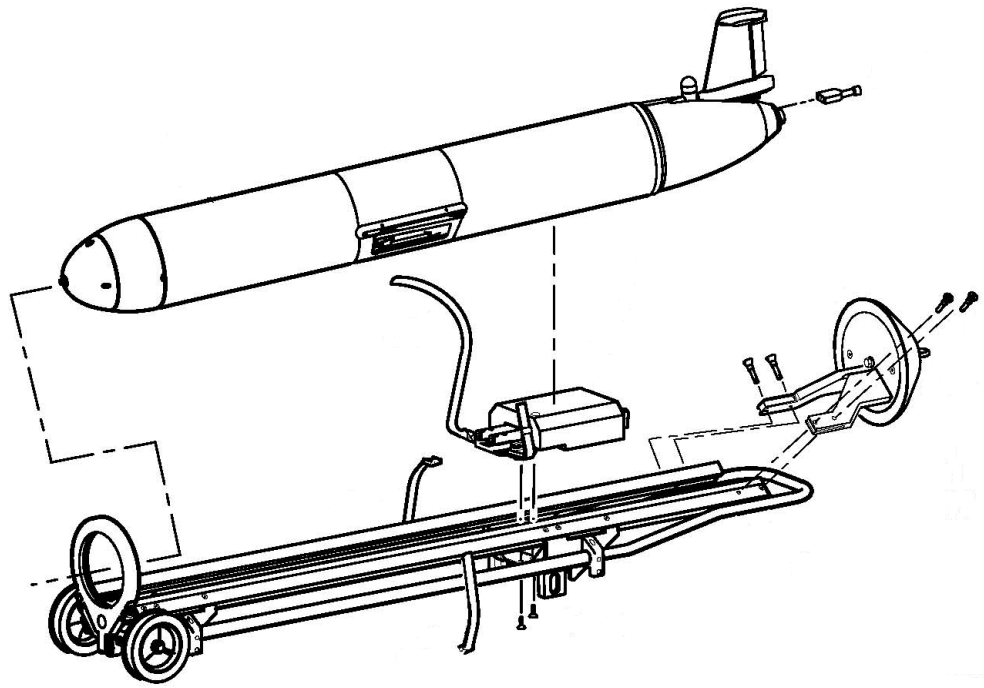

- Complete the Pre-Deployment Checkout Procedures found in reference (a).
- Connect the Docking Cone to the launch line and contact GOC prior to launch for a final Iridium communications and glider parameters check.
- Launch glider when ready. Ensure that the glider cart strap is disconnected and that the float release strap is the only strap holding the glider to the cart. Roll the glider cart wheels off the edge of the ship. In order for the Float Release Mechanism to work the cart must be submerged. Use tag lines attached to the rails of the glider cart to provide positive control of glider and cart during launch.
- Recover the glider cart and perform PM's or reset for next glider launch if/as necessary/desired. Contact the GOC to inform them the glider has been deployed.

Glider RHIB Launch

- Arrange a launch time with the GOC at least one week in advance. Call GOC 24 hours before launching to verify launch time. Call again one hour before the ship will be on station for the launch.
- Login and setup laptop with USB to serial converter and Freewave modem.
- Complete the Pre-Deployment Checkout Procedures found in reference (a).
- Load the glider into the RHIB with the glider attached to the cart and inform GOC you are heading to the Launch site.

- Due to the volatility of water density in coastal areas, attaching a line and a float to the glider that can be released after launching is recommended in order to verify that the glider was ballasted correctly. Also, attach a safety line to the glider cart with the other end attached to the RHIB.
- When at the launch site, position the cart so that the wheels are over the inflatable hull of the RHIB. Remove the strap holding the glider to the cart and lower the glider and cart into the water. The glider should float up off the cart. Release the safety line that was attached to the glider if one was used.
- Call the GOC to verify that the glider has been launched. Repeat these steps as necessary if additional gliders are to be launched.

NASA Maritime Aerosols Network Survey of Opportunity

Survey or Project Name

Maritime Aerosol Network

Points of Contact (POC)

<i>Lead POC or Principle Investigator (PI & Affiliation)</i>	<i>Supporting Team Members ashore</i>
POC: Dr. Alexander Smirnov	<i>Supporting Team Members aboard (if required)</i>

Activities Description(s) *(Include goals, objectives and tasks)*

The Maritime Aerosol Network (MAN) component of AERONET provides ship-borne aerosol optical depth measurements from the Microtops II sun photometers. These data provide an alternative to observations from islands as well as establish validation points for satellite and aerosol transport models. Since 2004, these instruments have been deployed periodically on ships of opportunity and research vessels to monitor aerosol properties over the World Oceans.

APPENDIX D. EK60 Calibration SOP



**Standard
Operating
Procedure**

EK60 Calibration

PROCESS OWNER	
NOAA Ship <i>Okeanos Explorer</i>	

REVISION HISTORY			
REV	Description of Change	Author	Effective Date
0	Initial release	Malik and Peters	August 2011
1	Revised		

REFERENCE DOCUMENTS	
Document Number	Document Title
	Simrad EK 60 Scientific Echo Sounder Reference Manual Release 2.2.0, January 2008

IMPORTANT: See pictures at end of this document for placement of outriggers on port and starboard side.

There is a recommended EK60 calibration procedure outlined in **Simrad EK60 Scientific Echo Sounder Reference Manual Release 2.2.0, January 2008**. The following procedures have been adapted for the *Okeanos Explorer*.



EK60 18kHz Transducer, installed May 2011. Arrows point towards the bow of the ship .The transducer is on the port side of the ship.

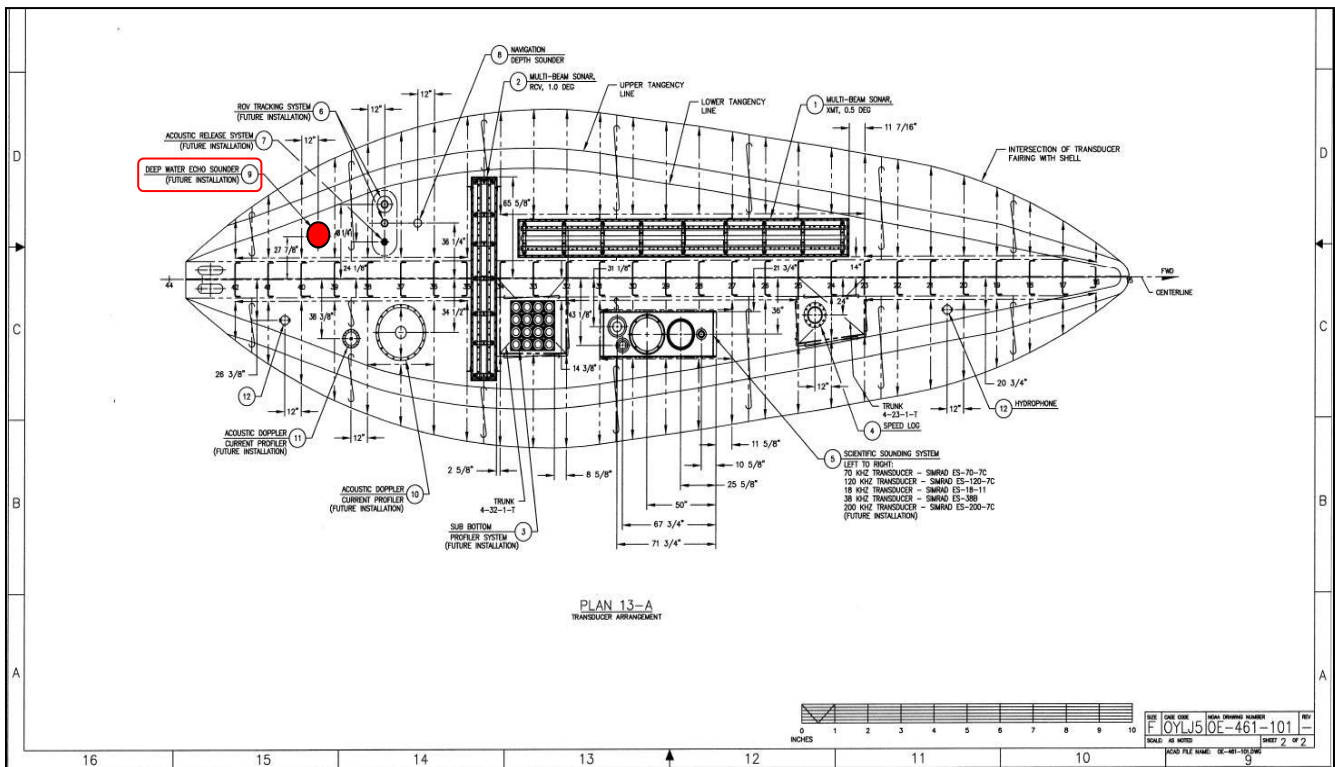

EX Transducer Arrangement. Not all of the labeled equipment is currently installed. Indicated is the location of the EK60 transducer. It is on the port side of the vessel.

1.0. Location

It is recommended to conduct calibration at a deep pier facility (with depth > 10 m). If no deep pier facility is available the calibration can be conducted at anchor in a location where there is minimal impact by fish (to avoid acoustic interference) and current/sea conditions (to avoid excessive movement which makes the mechanics of the calibration difficult). As a last resort, the calibration can be conducted while the ship is drifting. A final location will be chosen based on the impending weather conditions and discussions with the ship's command.

2.0. Equipment

The following equipment is required to conduct the calibration:

The following is provided by the EX and OER:

- 150 feet of line and a weight (ex: large shackle) secured in the center of the line.
 - *Shackle from Deck Department, line from Survey Department*
- EK 60 transducer and ER60 software
 - *These are installed on the ship.*
- 4 people minimum: 1 for each of 3 outriggers and at least 1 in the lab to conduct the calibration.
 - *Lead Scientist/Mapping Lead/Expedition Coordinator, Survey Technicians, Mapping personnel.*
- 4 handheld VHF radios
 - *Located in the Dry Lab.*



The following equipment was arranged by Kongsberg:

- 3 Downrigger reels
- 3 Outrigger poles
- Hardware to install outriggers to the side of the ship
- Calibration sphere (Copper, 63.0 mm diameter, temperature-dependent target strength)
- Swivels (to prevent twisting of the line)

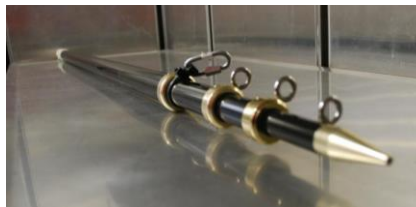

3.0. Pre Calibration

Significant preparations have to be made to set up the gear for EK 60 calibrations:

3.1. Equipment Setup:

1. Set up the reels and outriggers with two on the port side (fwd and aft) and one on the stbd side of the ship in line with location of hull installed EK 60 transducer.

The following is a diagram from the Simrad ER60 Scientific echo sounder software Reference Manual:

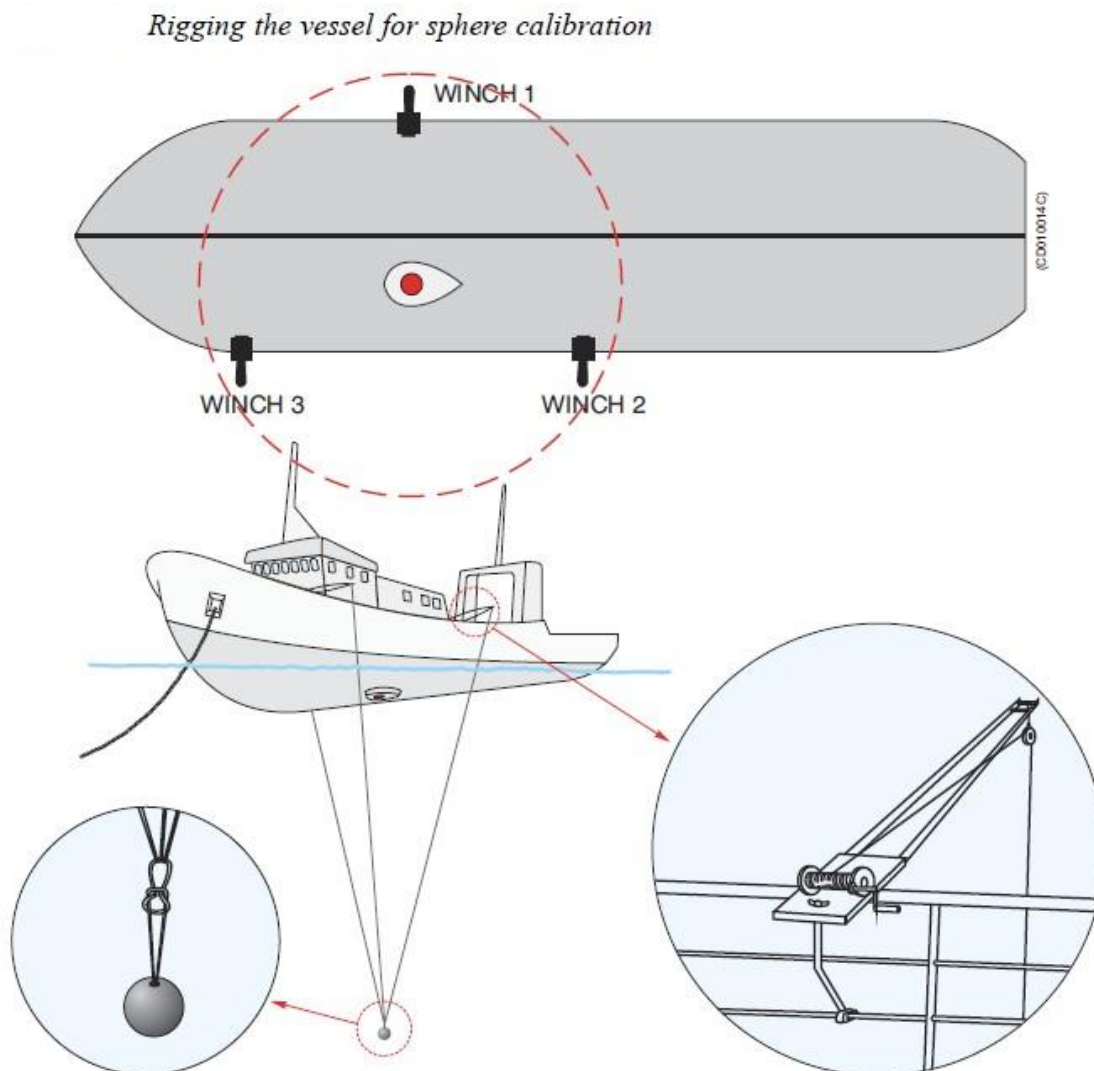

Each winch must be provided with a long spool of 0.60 mm diameter monofilament nylon line, which is marked with small swivels at 5 m intervals, beginning 10 m from the loose end. The purpose of the swivels is threefold:

- to unravel rotation of the nylon line
- to mark distances on the line
- to add weight so that the line sinks in water

Port Forward:

The orange board and L-bracket is clamped to the stanchion with u-bolts. The pole holder is then bolted to the L-bracket. A guide is configured by connecting a caribeaner onto a loop of line on the u-bolts and clipping in the line from the downrigger. This helps make a fair lead to the eyes on the outrigger pole.



This station is set up on the port side 0-1 deck, on the stanchion furthest forward.



Port Aft:

The orange L-bracket is u-bolted to the rail, then the orange board is u-bolted to the same rail. The pole holder is then bolted to the L-bracket. This station is mounted just forward of the chains on the port 01-deck forward of the breezeway.

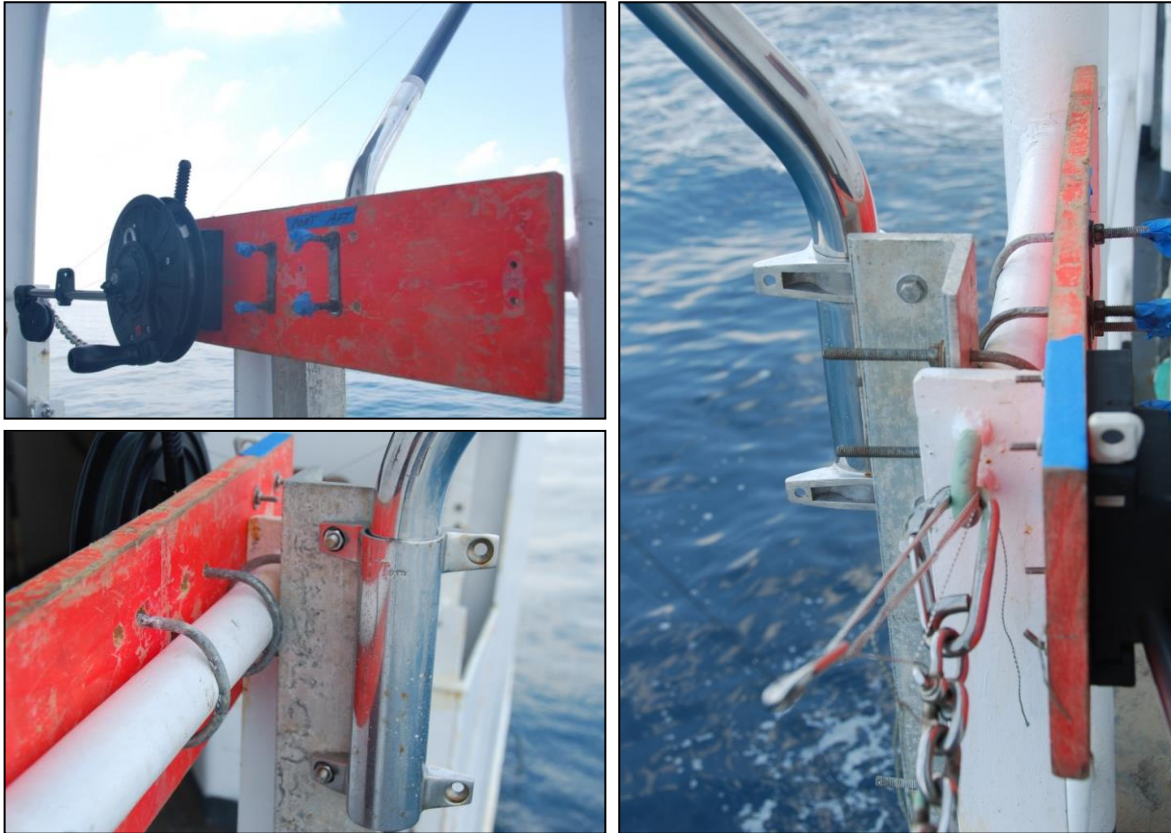

Starboard:



The L-bracket and pole holder are bolted onto the orange board. The L-bracket is then clamped to the L-shaped frame of the bulwarks. This station is set up between the 4th and 5th stanchions (counting forward to aft).

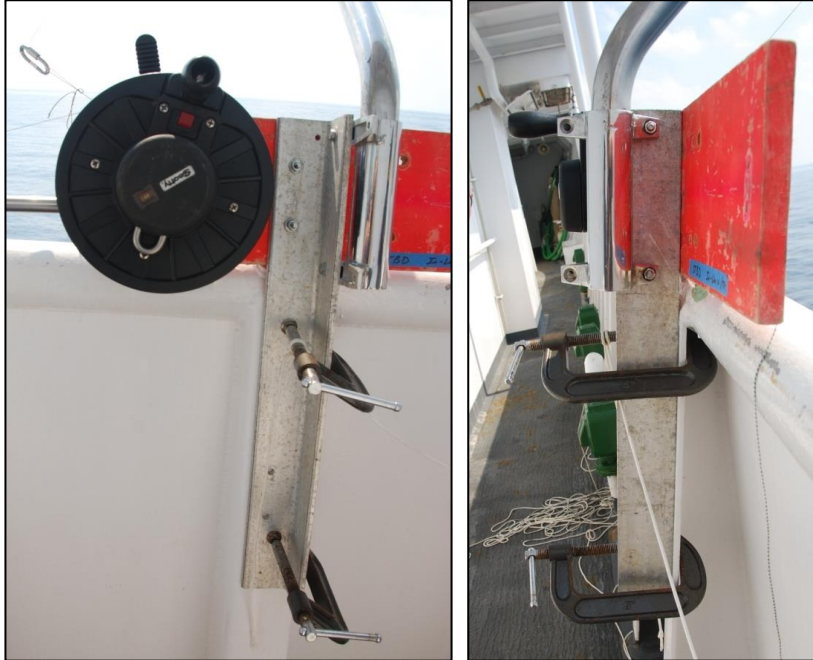

Once the mounting equipment is in place, the line can be run through the eyes of the poles, and the poles can be placed in the holders until it is time to connect the rest of the gear.

2. Take the line with the weight and be lower it into the water at the bow of the ship and then move aft holding the line on either side of the ship to bring the line under the ship's hull to the location of EK 60 transducer. This line will then be used to join the port and stbd filament line on the downriggers.
 - a. **Note: If anchoring, set up the line with the weight prior to anchoring or it will be difficult to get the line past the anchor on the bow.**
3. Clean the sphere with soapy water (purchase some Joy dish detergent on your next inport for this purpose!) to ensure there is no bio-fouling on the target.
4. Confirm that the vessel is secure in a suitable location (bow/stern anchored in still water that is free of biological scatterers, or drifting). If anchoring is not possible, calibration can be conducted while adrift.

3.2. CTD Cast:

A CTD cast is required to obtain a sound velocity measurement for the depth of the sphere. The CTD only needs to be lowered to about 50 meters. Once the cast is completed, print out a sound velocity profile for the top 50 meters of the water column. Once the sphere is lowered, and a depth

is determined, use the profile to select the appropriate sound velocity. You will also need the sound speed or temperature in order to select the correct sphere target strength during the calibration. The CTD cast will be conducted by the Ship's crew—OOD, SST and deck department.

3.3. Time Estimates:

It could take a few hours to precisely place the sphere under the EK 60. Up to 12 hours on-site may be required to conduct calibration. If additional time is available, it is recommended to collect data from both the EM 302 and the Knudsen while conducting EK 60.

NOTE: Make sure everyone working outside is cognizant of the weather conditions—to take breaks and wear sunblock in extreme heat or to bring suitable layers for cold weather—this process may take several hours. Also make sure to rotate personnel through the positions so that everyone can have enough breaks.

3.4. Risks:

Gear entanglement: The ship's motion during the calibration procedure should be minimal to avoid any gear entanglement. If gear entanglement is suspected, the calibration procedure will be halted and ship's divers will inspect the ship hull for any entanglement.

4.0. Calibration

Once the line with the weight has been draped below the ship's hull, and the vessel is secure either at anchor or adrift, the following methodology is the recommended approach for giving us the best control of the gear under the ship's hull.

4.1. Deployment

1) Attach one end of the line to a pole/reel on the stbd side of the vessel.

2) Pay out the monofilament on the stbd side reel, and pull in on the port side until the monofilament is reached. Detach the line, and attach the two remaining reels (e.g., fwd and aft port reels).

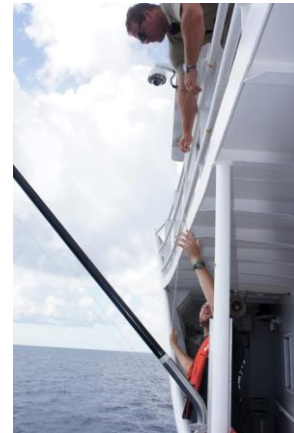

3) Attach a piece of monofilament, the calibration sphere, and a weight (weight needs to be at least one pulse length below the calibration sphere, and the sphere needs to be at least one pulse length between the swivel) to the point where the monofilament from all three reels are attached.

4) Soap the calibration sphere using ordinary

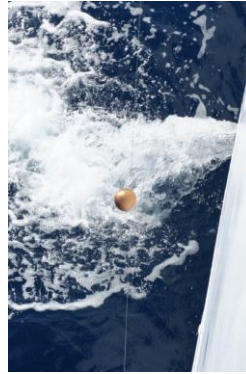

dish detergent to avoid bubble development on the surface of the sphere.

5) Lower the calibration sphere over the side until all three lines are equal (ideally, this will place the sphere underneath the EK60 transducer). The ship's drawing will be consulted to precisely position the reels.

6) Adjust the lines in order to conduct the calibration. This will require someone in the control room and on each reel, all with radios, to communicate the direction each reel needs to be operated to position the sphere.



7) The sphere needs to be moved into all four quadrants of the sonar beam. It is suggested to keep a written log of these changes in order to keep track of the motion of the sphere. Once the entire circle has been filled with points, the calibration is complete. (Consult section 5.0 for details of operating the calibration software. Make sure the raw data is being recorded. Also, the calibration can be re-examined in playback mode if necessary.

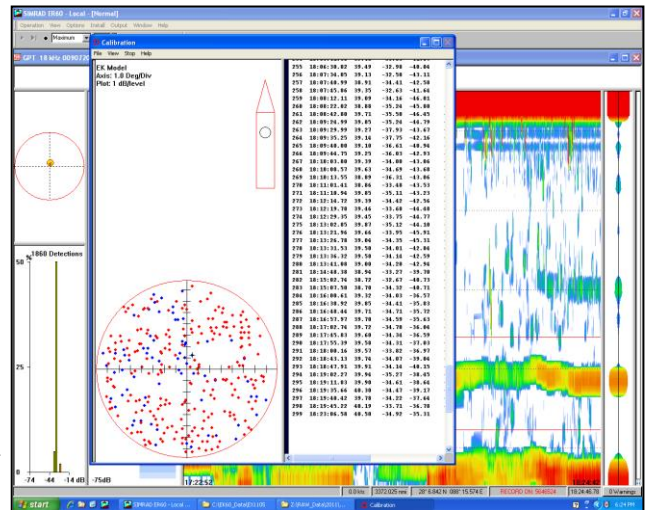
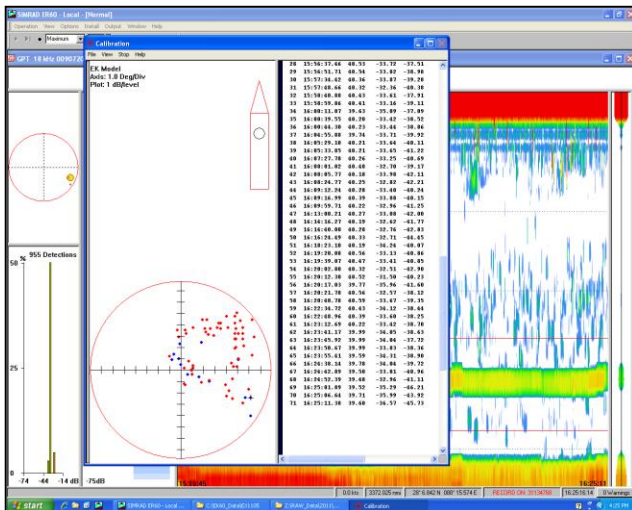

4.2. Recovery

- 1) After the calibration is finished, pay out the lines on port side and reel in on stbd until the stbd line is vertical and the connection point reaches the surface.
- 2) Next, grab the stbd line with a boat hook to bring it closer to the ship. Haul in the sphere and weight by hand until the gear is on deck.
- 3) Disconnect the sphere and the weights.
- 4) Disconnect the port lines and tell each person standing by the reels to haul in.
- 5) Inform the bridge when all equipment is out of the water and stowed.

4.0. Troubleshooting

- If the ship is drifting, and you cannot get the sphere into a particular quadrant simply by shifting the lines on the downriggers, consider turning the ship around. A shift in current direction may help get the sphere into the sector you need.

5.0. ERS 18 calibration software

Once the sphere has been lowered below the transducer, use the following procedure to run the calibration routine on the EK 60 software. The settings used for calibration on 08/29/2011 are provided as guidelines.

Setting up the calibration window

1. Click **Operation** → **Ping control**.
2. In the **Ping Control** dialogue, set **Ping rate** to *Interval* and *1 second*.
 - This can also be done from the toolbar.
3. Click **Operation** → **Normal**.
4. In the **Normal Operation** dialogue:
 - Select transceiver, and switch to *Active* mode.
 - Set the *Transmit Power* to the level you wish to calibrate [2000 W]
 - Choose the *Pulse Duration* you wish to calibrate [4.096 ms]

4.5 Start recording the raw data!

5. Right-click in an echogram, select **Range** on the short-cut menu, and set the range for one of the echogram views to cover the range you wish to see around the sphere. This range should include the depth range where you expect to find the reference target.
6. Check that you see the reference target in the *Single Echo* view.

7. Right-click in the *Single Echo* view corresponding to the echogram to open the **Single Target Detection** dialogue box.

8. In the **Single Target Detection** dialogue, click the **Calibration** button to start the calibration program, and to create a new *Calibration* window. The calibration program allows you to record new calibration data, or read previously recorded calibration data.

9. In the *Calibration* window, click **File** → **New** to open the **Record** dialogue and to start a new calibration.

10. Enter the following data in the **Record** dialogue box:

- a. Transducer's serial number [2097]
- b. Correct theoretical target strength (TS) for the reference target [e.g., -34.60 dB, dependent on sphere and sound speed at the calibration depth]
- *c. Allowed deviation from the TS for the reference target [5 dB]
- **d. Upper and lower depth limits for the target window
- e. Any comments you may wish to add to the calibration file

*This is a window giving the limits for the system's acceptance of single target echoes coming from fish. The closer to the correct reference target TS the limits have been set, the more of the unwanted fish echoes will be rejected. On the other hand, if the echo from the reference target is too close to one of the limits, the deviation has to be increased before starting collecting data. This is because it will always be a certain variation in TS values when the reference target is being moved to cover the complete beam.

**A narrow window will have same effect as above, reducing the possibility of detecting unwanted echoes from fish.

11. Click OK when you have finished entering data. The calibration program will now begin.

Running the calibration routine

Different views can be set up during the calibration. You will see two views in the *Calibration* window; a *Plot* view and an *Information* view. (screen grabs would be helpful here)

A vertical bar is shown on the left side of each view. A blue colour indicates that the view is active, while gray colour indicates a passive view. If you wish to print a view, or perform other operations connected to it, you must make sure that the desired view is active.

In the *Plot* view you will see recorded data plotted as blue and red circles. Blue circles indicate TS values below the current beam model, while red circles indicate values above the current beam model. In the upper part of the *Information* view you will see various information associated with recording of the calibration data. Lines containing this

information all begin with a #. Below this information, recorded values for each new TS detection are updated continuously during data recording.

1. Move the reference target slowly around to record a sufficient number of data points (>100) evenly distributed inside the beam. Make sure that a reasonable number of hits are made close to the centre of the beam. This is important in order to ensure a correct estimate for the Sa correction parameter.
2. While moving the target you should keep the reference target within the depth limits you entered in the **Record** dialogue.
3. While moving the target and recording of data points stops, the measured TS value may be outside the limits entered in the **Record** dialogue.
4. Stop and restart recording as required by using the **Stop/Start** command found in the **Main** menu. It is recommended to stop collecting data if unwanted fish echoes are entering into the depth window, and restart again when disappeared.
5. When you have finished data recording, click **File** → **Save As** to open the **Save As** dialogue.
6. Choose the directory where you want the calibration file to be saved, and enter a file name for your calibration file.
7. Click **Save** to finish.

The calibration program will now use two different models to fit recorded data, a polynomial model and a beam model. The *Plot* view will plot the model along with the recorded data points. Blue circles indicate values below the model; red circles indicate values above the model. The green circles close to the centre axis indicate the points that have been used when estimating the **Sa Correction value**.

Updating transducer parameters

When you are satisfied with the calibration results you can use the results to update your transducer parameters in the echo sounder.

1. In the *Calibration* window, click **File** → **Update Beam Data** to perform this task.

Note

This is a serious operation, which will affect the transducer installation parameters and will thus affect all future results to be obtained using the current transducer and pulse duration. Thus, to prevent accidentally use of this operation, you are asked to confirm this operation. The changes take effect automatically the next time you start normal operations on the echo sounder.

August 29, 2011 calibration results

(Tom)

```

# Calibration Version 2.1.0.12
#
# Date: 8/29/2011
#
# Comments:
#
# Reference Target:
#   TS -34.60 dB Min. Distance 36.00 m
#   TS Deviation 5.0 dB Max. Distance 47.00 m
#
# Transducer: ES18-11 Serial No. 2097
#   Frequency 18000 Hz Beamtype Split
#   Gain 23.00 dB Two Way Beam Angle -17.2 dB
#   Athw. Angle Sens. 13.90 Along. Angle Sens. 13.90
#   Athw. Beam Angle 10.60 deg Along. Beam Angle 10.40 deg
#   Athw. Offset Angle 0.00 deg Along. Offset Angle 0.00 deg
#   SaCorrection 0.00 dB Depth 4.57 m
#
# Transceiver: GPT 18 kHz 009072066c0e 1-1 ES18-11
#   Pulse Duration 4.096 ms Sample Interval 0.771 m
#   Power 2000 W Receiver Bandwidth 0.72 kHz
#
# Sounder Type:
#   EK60 Version 2.2.1
#
# TS Detection:
#   Min. Value -38.0 dB Min. Spacing 100 %
#   Max. Beam Comp. 6.0 dB Min. Echolength 80 %
#   Max. Phase Dev. 10.0 Max. Echolength 470 %
#
# Environment:
#   Absorption Coeff. 1.5 dB/km Sound Velocity 1505.0 m/s
#
# Beam Model results:
#   Transducer Gain = 23.09 dB SaCorrection = -0.43 dB
#   Athw. Beam Angle =10.93 deg Along. Beam Angle =10.61 deg
#   Athw. Offset Angle = 0.17 deg Along. Offset Angle= 0.03 deg
#
# Data deviation from beam model:
#   RMS = 0.42 dB
#   Max = 1.21 dB No. = 228 Athw. = -5.2 deg Along = -2.8 deg
#   Min = -1.87 dB No. = 263 Athw. = -1.2 deg Along = 5.0 deg
#
# Data deviation from polynomial model:
#   RMS = 0.39 dB
#   Max = 1.16 dB No. = 228 Athw. = -5.2 deg Along = -2.8 deg
#   Min = -1.66 dB No. = 263 Athw. = -1.2 deg Along = 5.0 deg
#
# Data:
#   No. Time Distance TS-c TS-u Athw. Along sA
#   [m] [dB] [dB] [deg] [deg] [m2/nm2]
#
# 1 15:39:55.89 40.42 -34.54 -34.81 1.11 0.20 482

```

2	15:40:00.64	40.41	-34.56	-34.74	0.91	0.00	484
3	15:42:04.39	40.37	-34.43	-34.74	1.11	0.40	516
////////							
////////							
295	18:19:11.83	39.90	-34.61	-38.64	-3.24	2.93	207
296	18:19:35.66	40.30	-34.47	-39.17	-3.54	3.14	154
297	18:19:40.42	39.78	-34.22	-37.64	-2.73	2.93	257
298	18:19:45.22	40.19	-33.71	-36.78	-2.63	2.73	308
299	18:23:06.58	40.50	-34.92	-35.31	0.51	1.21	444

Port Aft Position



Port Forward Position



Starboard Forward Position

